

SECTION 7

Note: Click on the content title or page number(s) to jump to the first page of that subject.

GENERAL

Voltage Drop Factors..... 7-2-13 and 7-2-14
Amperes to KVA 7-2-15
KVA to Amperes 7-2-16

SPACE CONDITIONING and GENERAL SERVICE

Metering of Customer Owned Generation..... 7-12-1 to 7-12-9
Time of Day Space Conditioning D1.7 Residential..... 7-13-1 to 7-13-3
Experimental Electric Vehicle Rate D1.9 Residential..... 7-14-1 to 7-14-3
Interruptible Space Conditioning D1.1 Residential 7-15-1 to 7-15-9
Interruptible Space Conditioning D1.1 Commercial 7-15-10 to 7-15-12
Interruptible Space Conditioning D1.1 Multiple Occupancy 7-15-17 to 7-15-20
Interruptible Space Conditioning D1.1 Alternate Circuit 7-15-25
Interruptible Space Conditioning D1.1 Mobile Home..... 7-15-26 to 7-15-28
Interruptible Space Conditioning D1.1 Rate Applications 7-15-35 to 7-15-39
Interruptible General Service D3.3 7-17-1 to 7-17-6
Residential Supplemental Space Heating D1.5 7-18-1 and 7-18-2

WATER HEATING

Wiring Connections for Self-Contained Meters 7-23-1
Wiring Connections for CT Cabinets 7-23-2
480 V Single-Phase Water Heaters..... 7-23-3
Contactor Controlled Water Heaters..... 7-23-4 and 7-23-5
Relay Controlled Multiple and High Power Water Heaters 7-23-6
Multiple Water Heaters--One Customer..... 7-24-1 and 7-24-2
Farm Buildings..... 7-24-3 and 7-24-4
Multiple Occupancy Buildings 7-25-1 to 7-25-3
Mobile Homes..... 7-27-1 to 7-27-4
Water Heater Wiring Connections..... 7-28-1
Farm Building Grounding Requirements..... 7-29-1 to 7-29-5
Water Heater Wiring Diagrams (1)..... 7-30-5 and 7-30-6
Water Heater Wiring Diagrams (2)..... 7-31-1

VOLTAGE DROP FACTORS

60° C (140° F) Operating Temperature at 60 Cycle Frequency and Any Voltage

Results from these factors are accurate enough for practical purposes. Standard electrical and engineering reference texts are recommended where closer accuracy is desired.

This table shows circuit voltage drop only.

A – Copper in iron conduit B – Copper in non-magnetic conduit or close spaced
C – Aluminum in iron conduit D – Aluminum in non-magnetic conduit or closed space

Wire Size	Single Phase 100% P. F.			Single Phase 80% P. F.				Three Phase 80% P. F.			
	A or B	C	D	A	B	C	D	A	B	C	D
14	61.00	----	----	49.64	49.36	---	---	43.00	42.80	---	---
12	38.28	60.40	60.40	31.38	31.12	49.20	49.00	27.20	27.00	42.60	42.50
10	24.04	38.00	38.00	20.03	19.78	31.10	31.00	17.33	17.13	36.90	26.80
8	15.20	23.90	23.90	12.95	12.68	19.90	19.70	11.20	11.00	17.25	17.01
6	9.70	15.30	15.30	8.50	8.25	13.00	12.80	7.35	7.15	11.26	11.10
4	6.14	9.66	9.66	5.62	5.38	8.38	8.26	4.87	4.66	7.26	7.15
2	3.82	6.06	6.06	3.72	3.50	5.46	5.34	3.22	3.03	4.73	4.62
1	3.06	4.80	4.80	3.12	2.89	4.46	4.34	2.70	2.51	3.86	3.76
0	2.41	3.82	3.82	2.59	2.37	3.66	3.54	2.24	2.06	3.17	3.07
2/0	1.92	3.02	3.02	2.17	1.96	3.00	2.90	1.88	1.70	2.60	2.31
3/0	1.52	2.42	2.40	1.83	1.63	2.50	2.38	1.58	1.41	2.17	2.06
4/0	1.21	1.94	1.92	1.56	1.36	2.10	1.97	1.35	1.18	1.82	1.71
250m	1.03	1.64	1.61	1.42	1.22	1.88	1.74	1.23	1.06	1.63	1.51
300m	0.86	1.37	1.34	1.28	1.09	1.64	1.52	1.11	0.95	1.42	1.32
350m	0.73	1.18	1.15	1.17	0.98	1.48	1.35	1.01	0.85	1.28	1.17
400m	0.64	1.05	1.01	1.10	0.90	1.36	1.24	0.95	0.78	1.20	1.07
500m	0.52	0.85	0.81	0.98	0.80	1.20	1.06	0.85	0.69	1.04	0.92

NOTE: May be used for D.C. with small inaccuracy

VOLTAGE DROP FACTORS (Cont'd.)**EXPLANATION**

- To find the voltage drop in a given circuit knowing wire size and load, carry out the following calculation:

$$\frac{\text{FEET OR CIRCUIT LENGTH} \times \text{AMPERES} \times \text{VOLTAGE DROP FACTOR}}{10,000} = \text{VOLTAGE DROP}$$

$$\frac{\text{VOLTS DROP} \times 100}{\text{LINE VOLTAGE}} = \% \text{ of drop}$$

(230 Volts, 2.3 Volts = 1%: 4.6 Volts = 2%: 6.9 Volts = 3%: 115 Volts, 3.45 Volts = 3%)

Example:

Find the voltage drop for a three-phase circuit of #4 wire in iron conduit 207 feet long carrying 55 amperes (any voltage) at 80% power factor.

$$\text{COPPER } \frac{207 \times 55 \times 4.87}{10,000} = 5.54 \text{ VOLTS DROP } \frac{5.54 \times 100}{230} = 2.41\%$$

$$\text{ALUMINUM } \frac{207 \times 55 \times 7.26}{10,000} = 8.27 \text{ VOLTS DROP } \frac{8.27 \times 100}{230} = 3.59\%$$

- To find size wire necessary for a given load with a given circuit length and a desired voltage drop, carry out the following calculation:

$$\frac{\text{DESIRED VOLTAGE DROP} \times 10,000}{\text{CIRCUIT LENGTH IN FEET} \times \text{AMPERES}} = \text{VOLTAGE DROP FACTOR FOR WIRE SIZE}$$

Example:

For a single-phase load of 225 amperes (any voltage) at 80% power factor and a copper circuit 168 feet long in iron conduit on which it is desired to keep the voltage drop at 4.8 the wire size is determined as follows:

$$\frac{4.8 \times 10,000}{168 \times 225} = 1.27$$

From the single-phase 80% P. F. "A" Column of the table it will be found that the nearest Voltage Drop Factor is 1.28. The wire size corresponding to this Voltage Drop Factor is 300,000 circular mils.

CONVERSION TABLE – AMPERES TO KVA

Amps	KVA			
	240		480	
	1Φ	3Φ	1Φ	3Φ
10	2.40	4.16	4.80	8.31
11	2.64	4.57	5.28	9.15
12	2.88	4.99	5.76	9.98
13	3.12	5.40	6.24	10.81
14	3.36	5.82	6.72	11.64
15	3.60	6.24	7.20	12.47
16	3.84	6.65	7.68	13.30
17	4.08	7.07	8.16	14.13
18	4.32	7.48	8.64	14.96
19	4.56	7.90	9.12	15.80
20	4.80	8.31	9.60	16.63
21	5.04	8.73	10.08	17.46
22	5.28	9.15	10.56	18.29
23	5.52	9.56	11.04	19.12
24	5.76	9.98	11.52	19.95
25	6.00	10.39	12.00	20.78
26	6.24	10.81	12.48	21.62
27	6.48	11.22	12.96	22.45
28	6.72	11.64	13.44	23.28
29	6.96	12.06	13.92	24.11
30	7.20	12.47	14.40	24.94
31	7.44	12.89	14.88	25.77
32	7.68	13.30	15.36	26.60
33	7.92	13.72	15.84	27.44
34	8.16	14.13	16.32	28.27
35	8.40	14.55	16.80	29.10
36	8.64	14.96	17.28	29.93
37	8.88	15.38	17.76	30.76
38	9.12	15.80	18.24	31.59
39	9.36	16.21	18.72	32.42
40	9.60	16.63	19.20	33.26
41	9.84	17.04	19.68	34.09
42	10.08	17.46	20.16	34.92
43	10.32	17.87	20.64	35.75
44	10.56	18.29	21.12	36.58
45	10.80	18.71	21.60	37.41
46	11.04	19.12	22.08	38.24
47	11.28	19.54	22.56	39.08
48	11.52	19.95	23.04	39.91
49	11.76	20.37	23.52	40.74
50	12.00	20.78	24.00	41.57
51	12.24	21.20	24.48	42.40
52	12.48	21.62	24.96	43.23
53	12.72	22.03	25.44	44.06
54	12.96	22.45	25.92	44.89

Amps	KVA			
	240		480	
	1Φ	3Φ	1Φ	3Φ
55	13.20	22.86	26.40	45.73
56	13.44	23.28	26.88	46.56
57	13.68	23.69	27.36	47.39
58	13.92	24.11	27.84	48.22
59	14.16	24.53	28.32	49.05
60	14.40	24.94	28.80	49.88
61	14.64	25.36	29.28	50.71
62	14.88	25.77	29.76	51.55
63	15.12	26.19	30.24	52.38
64	15.36	26.60	30.72	53.21
65	15.60	27.02	31.20	54.04
66	15.84	27.44	31.68	54.87
67	16.08	27.85	32.16	55.70
68	16.32	28.27	32.64	56.53
69	16.56	28.68	33.12	57.37
70	16.80	29.10	33.60	58.20
71	17.04	29.51	34.08	59.03
72	17.28	29.93	34.56	59.86
73	17.52	30.35	35.04	60.69
74	17.76	30.76	35.52	61.52
75	18.00	31.18	36.00	62.35
76	18.24	31.59	36.48	63.19
77	18.48	32.01	36.96	64.02
78	18.72	32.42	37.44	64.85
79	18.96	32.84	37.92	65.68
80	19.20	33.26	38.40	66.51
81	19.44	33.67	38.88	67.34
82	19.68	34.09	39.36	68.17
83	19.92	34.50	39.84	69.00
84	20.16	34.92	40.32	69.84
85	20.40	35.33	40.80	70.67
86	20.64	35.75	41.28	71.50
87	20.88	36.17	41.76	72.33
88	21.12	36.58	42.24	73.16
89	21.36	37.00	42.72	73.99
90	21.60	37.41	43.20	74.82
91	21.84	37.83	43.68	75.66
92	22.08	38.24	44.16	76.49
93	22.32	38.66	44.64	77.32
94	22.56	39.08	45.12	78.15
95	22.80	39.49	45.60	78.98
96	23.04	39.91	46.08	79.81
97	23.28	40.32	46.56	80.64
98	23.52	40.74	47.04	81.48
99	23.76	41.15	47.52	82.31
100	24.00	41.57	48.00	83.14

CONVERSION TABLE – KVA TO AMPERES

KVA	Amperes			
	240		480	
	1Φ	3Φ	1Φ	3Φ
10	41.67	24.06	20.83	12.03
11	45.83	26.46	22.92	13.23
12	50.00	28.87	25.00	14.43
13	54.17	31.27	27.08	15.64
14	58.33	33.68	29.17	16.84
15	62.50	36.08	31.25	18.04
16	66.67	38.49	33.33	19.25
17	70.83	40.90	35.42	20.45
18	75.00	43.30	37.50	21.65
19	79.17	45.71	39.58	22.85
20	83.33	48.11	41.67	24.06
21	87.50	50.52	43.75	25.26
22	91.67	52.92	45.83	26.46
23	95.83	55.33	47.92	27.66
24	100.00	57.74	50.00	28.87
25	104.17	60.14	52.08	30.07
26	108.33	62.55	54.17	31.27
27	112.50	64.95	56.25	32.48
28	116.67	67.36	58.33	33.68
29	120.83	69.76	60.42	34.88
30	125.00	72.17	62.50	36.08
31	129.17	74.57	64.58	37.29
32	133.33	76.98	66.67	38.49
33	137.50	79.39	68.75	39.69
34	141.67	81.79	70.83	40.90
35	145.83	84.20	72.92	42.10
36	150.00	86.60	75.00	43.30
37	154.17	89.01	77.08	44.50
38	158.33	91.41	79.17	45.71
39	162.50	93.82	81.25	46.91
40	166.67	96.23	83.33	48.11
41	170.83	98.63	85.42	49.32
42	175.00	101.04	87.50	50.52
43	179.17	103.44	89.58	51.72
44	183.33	105.85	91.67	52.92
45	187.50	108.25	93.75	54.13
46	191.67	110.66	95.83	55.33
47	195.83	113.06	97.92	56.53
48	200.00	115.47	100.00	57.74
49	204.17	117.88	102.08	58.94
50	208.33	120.28	104.17	60.14
51	212.50	122.69	106.25	61.34
52	216.67	125.09	108.33	62.55
53	220.83	127.50	110.42	63.75
54	225.00	129.90	112.50	64.95

KVA	Amperes			
	240		480	
	1Φ	3Φ	1Φ	3Φ
55	229.17	132.31	114.58	66.15
56	233.33	134.72	116.67	67.36
57	237.50	137.12	118.75	68.56
58	241.67	139.53	120.83	69.76
59	245.83	141.93	122.92	70.97
60	250.00	144.34	125.00	72.17
61	254.17	146.74	127.08	73.37
62	258.33	149.15	129.17	74.57
63	262.50	151.55	131.25	75.78
64	266.67	153.96	133.33	76.98
65	270.83	156.37	135.42	78.18
66	275.00	158.77	137.50	79.39
67	279.17	161.18	139.58	80.59
68	283.33	163.58	141.67	81.79
69	287.50	165.99	143.75	82.99
70	291.67	168.39	145.83	84.20
71	295.83	170.80	147.92	85.40
72	300.00	173.21	150.00	86.60
73	304.17	175.61	152.08	87.81
74	308.33	178.02	154.17	89.01
75	312.50	180.42	156.25	90.21
76	316.67	182.83	158.33	91.41
77	320.83	185.23	160.42	92.62
78	325.00	187.64	162.50	93.82
79	329.17	190.04	164.58	95.02
80	333.33	192.45	166.67	96.23
81	337.50	194.86	168.75	97.43
82	341.67	197.26	170.83	98.63
83	345.83	199.67	172.92	99.83
84	350.00	202.07	175.00	101.04
85	354.17	204.48	177.08	102.24
86	358.33	206.88	179.17	103.44
87	362.50	209.29	181.25	104.64
88	366.67	211.70	183.33	105.85
89	370.83	214.10	185.42	107.05
90	375.00	216.51	187.50	108.25
91	379.17	218.91	189.58	109.46
92	383.33	221.32	191.67	110.66
93	387.50	223.72	193.75	111.86
94	391.67	226.13	195.83	113.06
95	395.83	228.53	197.92	114.27
96	400.00	230.94	200.00	115.47
97	404.17	233.35	202.08	116.67
98	408.33	235.75	204.17	117.88
99	412.50	238.16	206.25	119.08
100	416.67	240.56	208.33	120.28

METERING OF CUSTOMER OWNED GENERATION

1. **General**

Customer Owned Generation Equipment (COGE) is electric generation equipment installed on the customer side of electric meter. COGE operates in parallel with the electric utility grid.

Examples include: Wind Turbines, Solar Panels referred to as Photovoltaic, Hydropower, Fuel Cells, Biomass, Natural Gas, Gasoline, or Diesel powered generators.

If you are considering installing COGE, please contact DTE. DTE interconnection requirements must be met to ensure your safety, DTE crews' safety, and the electric grid reliability. Depending on COGE type, the customer has several rate options to choose from. Click on the link before for detail on the rate options. <http://www.dteenergy.com/residentialCustomers/productsPrograms/generate/rateOptions.html>

Customers should consult Section 5 (5-1 and 5-2) of the Electrical Service Installation Guide for further information pertaining to Meters and Service Equipment and Enclosures.

2. **Meter and Service Equipment**

Depending on the rate type and metering equipment functionality the metering equipment could consist of:

- one bidirectional meter, or
- two meters in a bidirectional configuration, or
- one bidirectional meter and one generation meter, or
- Two meters in a bidirectional configuration and one generation meter.

Consult DTE Energy Interconnection Team to determine the applicable configuration for the site.

Meter Identification.

- a. The generation meter will be labeled "GEN. METER" and will record ALL Generation. "GEN. METER" must be electrically connected in series with any power production equipment and ahead of all electrical loads.
- b. When two meters in a bidirectional configuration:
 1. One meter will be labeled, "INFLOW METER", and will record electrical consumption from DTE Electric.
 2. A second meter will be located next to the "INFLOW METER", and will be labeled, "OUTFLOW METER". This meter will record excess power production exported to DTE Electric.

Additional labels should be permanently affixed inside the meter enclosures, NOT on the enclosure covers.

3. **Installation Guidelines**

The meter enclosures must comply with all applicable requirements found in SIM-ESIG sections 3, 4 and 5. All enclosures should be single position and will be treated as a single enclosure under the requirements. See Section 5-3 and National Electrical Code (NEC) Article 110 for working space requirements.

- (a) Maximum of 6'-0" from top of meter enclosure to floor or final grade.
- (b) Minimum 3'-6" from center of meter face to floor or final grade.

For any rate that requires multiple meter enclosures, the single position meter enclosures should be mounted in close proximity to each other. All meter enclosures together should occupy a 5 foot horizontal space and have a minimum separation of one inch (See page 7-12-5).

When the "INFLOW" and "OUTFLOW" enclosures are mounted one on top of each other, the hub sizes should be at least 2" for 200 ampere enclosures. The "INFLOW" and "OUTFLOW" enclosures' current and voltage ratings must comply with Customer's approved service. Consult with the Interconnection Team for more information.

For **Current Transformer (CT)** rated service, consult with DTE Energy Interconnection team prior to installation of the metering equipment. If determined that "INFLOW" and "OUTFLOW" meters are required, then below are the 2 commonly occurred scenarios.

Scenario 1:

If the existing meter enclosure is NOT an "S" base CT rated meter enclosure, then it must be replaced with an "S" base CT rated meter enclosure. Another "S" base CT rated meter enclosure is required to be installed for the "OUTFLOW" meter.

Scenario 2:

If the existing meter enclosure is an "S" base meter enclosure, then install an "S" base CT rated meter enclosure for the "OUTFLOW" meter.

Customer is responsible to furnish and install the meter enclosure(s) and conduit required for metering. For CT rated service that requires "INFLOW" and "OUTFLOW" setup, DTE Energy is responsible for the wiring of the current transformers to the "INFLOW" and "OUTFLOW" meter enclosures.

Refer to the Service Installation Manual, section 5-4, Current Transformer Cabinet, for complete guidelines.

All self contained and CT rated enclosures must conform to Service Installation Manual (SIM-ESIG) sections 5 and 7 requirements. Class 100 meter enclosures are not acceptable.

Additionally all hubs, wireways, conduits and associated wiring must comply with all applicable laws and the rules of the governmental authority having jurisdiction (AHJ), and current NEC.

4. **Customer Responsibilities**

The COGE, service and associated wiring must comply with all of the following:

- (a) Michigan Interconnection Rules/Process – The overview of the process could be found on DTE Energy website under Generate My Own Power at <http://www.dteenergy.com/residentialCustomers/productsPrograms/generate/interconnectionProcess.html>
- (b) All applicable laws and the rules of the governmental authority having jurisdiction (AHJ).
- (c) The current National Electrical Code.
- (d) The customer is responsible for all costs associated with the installation. The Service wiring must conform to SIM-ESIG.
- (e) Customer Owned Generation Equipment, (COGE), Safety Switch: The customer is required to install a COGE Safety Switch between the inverter and the Generation Meter. This is a requirement for any kind of generation or storage device. In instances where a generation meter is not required, the COGE Safety Switch must be installed between the inverter or synchronous generator and the customer's Main Service Panel, (MSP), that is fed directly from the revenue meter. The COGE Safety Switch must provide a means for a visible break of the interconnection system only. The COGE Safety Switch must be mounted in close proximity to the metering equipment within 5 feet. The COGE Safety Switch must be visible from the metering equipment an operable from the ground. Refer to Service Installation Manual, (SIM), section 5 for more detail. Fused Pull-Out and Circuit Breakers are not acceptable. The COGE Safety Switch cannot branch to support any customer load, (e.g. a feed to a garage for lighting, an auxiliary structure, a light in a pole in the yard, or anything else). The COGE Safety Switch must ONLY control the interconnected generation and/or storage.
- (f) Contact Interconnection Hotline at 1.313.235.4333 for further assistance.

- (g) For self-contained Network services (120/208 volts) it is the customers' responsibility to provide the 5th jaw terminal that is needed for any meter enclosure.
- (h) Utilizing the meter enclosure(s) as a wiring raceway is prohibited.
- (i) Since the Neutral and Ground Busses are bonded together in the Main Service panel, the GEN METER enclosure would be grounded via the neutral wire connected from the Main Service Panel. If the GEN METER enclosure is connected to other ground source(s), isolation is required between the neutral connection and other ground source(s).
- (j) The generator output shall be connected to the line side in the "GEN" meter enclosure.
- (k) **For CT rated service**, the load side of the "GEN" meter enclosure could be connected to the load side in the Current Transformer cabinet. Approval by the Interconnection Team is required prior to make the connection.
- (l) **For Self Contained service**, the load side of the "GEN" meter enclosure shall be connected to the customer circuit panel. In rare circumstances, DTE Electric may approve to connect the load side of the meter enclosure to a tap box that is installed between the main meter and Main Circuit Breaker. It is not acceptable to connect the "GEN" meter directly to the load side of the existing meter enclosure. Consult with the Interconnection Team for approval prior to installation. See drawing on page 7-12-08.
- (m) Meter enclosures – The customer is required to install DTE approved meter enclosure(s). The list of the approved meter enclosures can be found in section 5, starting at page 5-8-13.

Failure to follow the outlined requirement and specifications could result delaying the completion of the service. Please call the Interconnection Hotline (1.313.235.4333) if there are additional questions regarding requirements of a specific generation site.

5. Reference

Section 5 – Service Equipment manual can be found on DTE Energy website, by clicking on the link: <http://www.dteenergy.com/pdfs/serviceEquipment.pdf>

TYPICAL METER EQUIPMENT LAYOUT

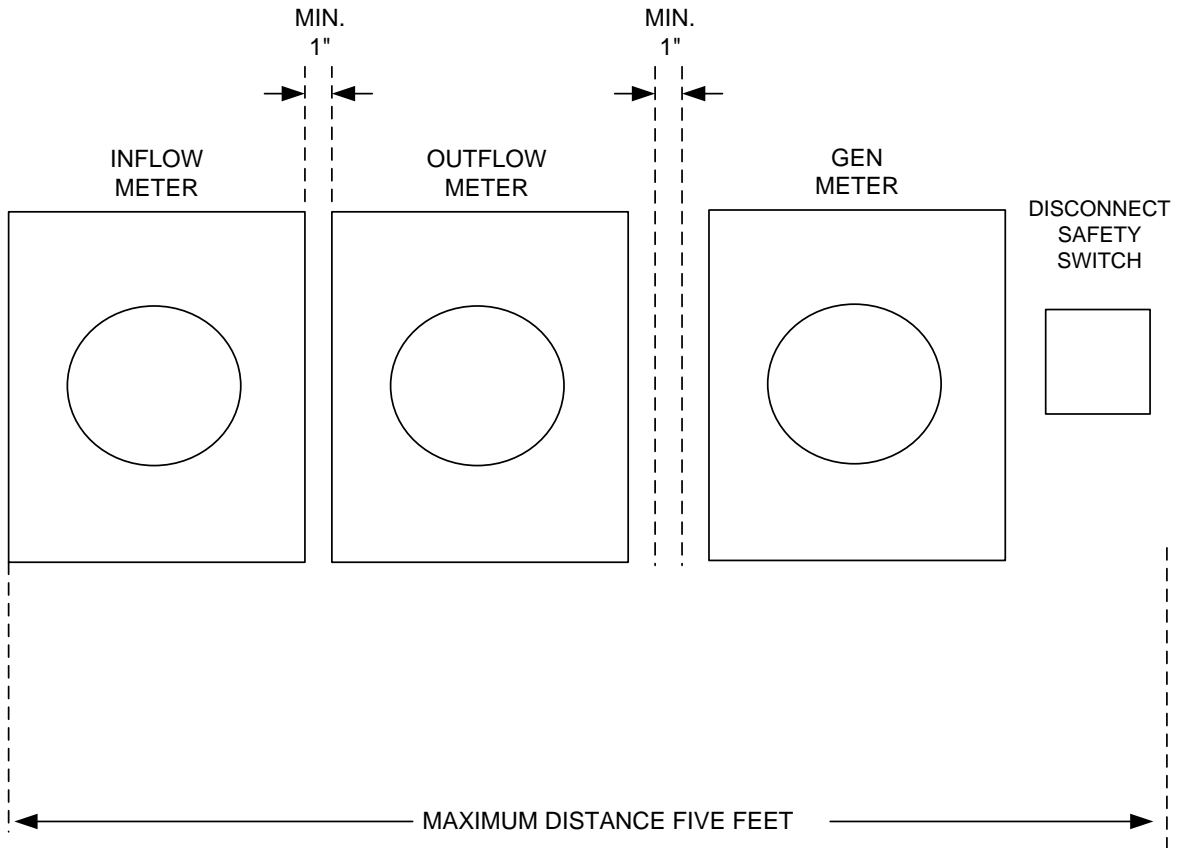

NOTE: VERTICAL CLEARANCES – SEE PAGE 5-3-2, ITEM (13).

THE DETROIT EDISON COMPANY ASSUMES NO RESPONSIBILITY FOR INJURY OR DAMAGE ARISING FROM THE USE OF THIS SPECIFICATION DIAGRAM

UNDERGROUND FEED
METERING EXAMPLE USING SERVICE RATED TROUGH

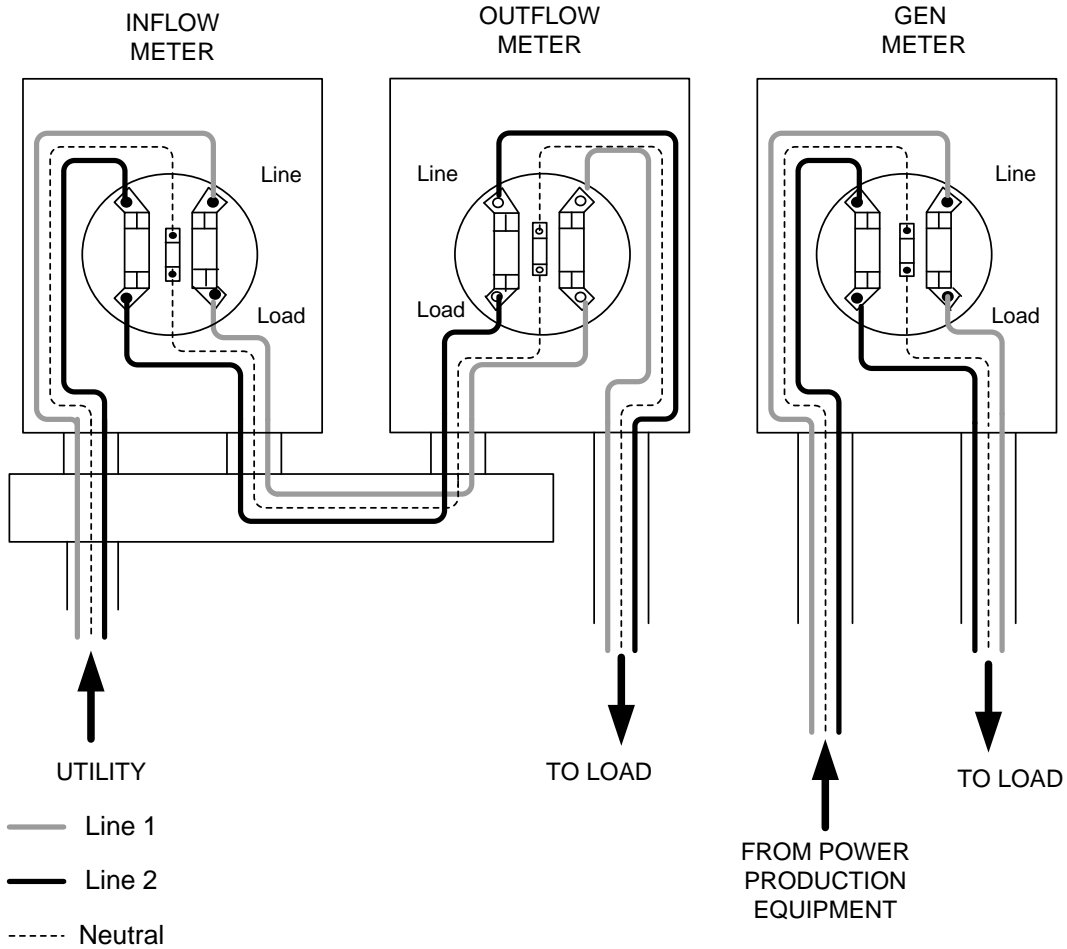

NOTE 1: Neutral Wire from the Power Production Equipment is optional if the service is Single phase, 3 Wire, 120/240V.

NOTE 2: Isolation is required between the Neutral and Ground sources at the GEN METER enclosure. For reference, please see section 5 – “Service Equipment” manual

NOTE 3: SAFETY SWITCH (Must be installed between the output of the INVERTER and the GEN METER)

THE DETROIT EDISON COMPANY ASSUMES NO RESPONSIBILITY FOR INJURY OR DAMAGE ARISING FROM THE USE OF THIS SPECIFICATION DIAGRAM

OVERHEAD FEED
METERING EXAMPLE USING SERVICE RATED TROUGH

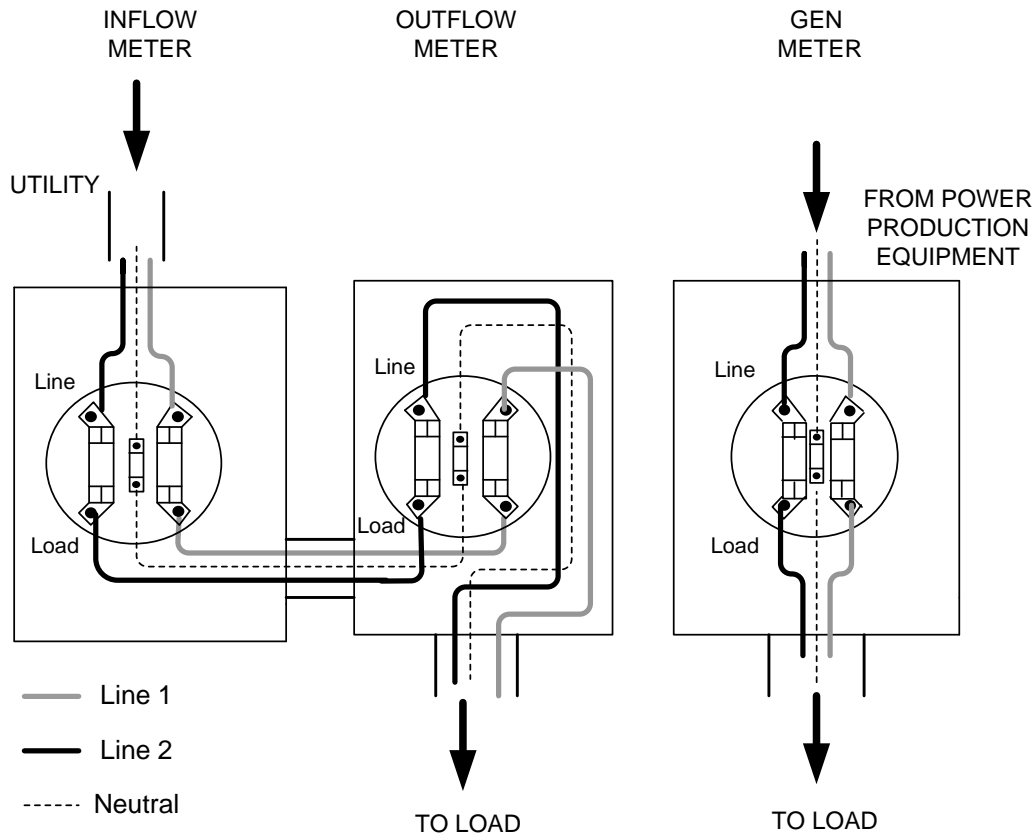

NOTE 1: Neutral Wire from the Power Production Equipment is optional if the service is Single phase, 3 Wire, 120/240V.

NOTE 2: Isolation is required between the Neutral and Ground sources at the GEN METER enclosure. For reference, please see section 5 – “Service Equipment” manual

NOTE 3: SAFETY SWITCH (Must be installed between the output of the INVERTER and the GEN METER)

THE DETROIT EDISON COMPANY ASSUMES NO RESPONSIBILITY FOR INJURY OR DAMAGE ARISING FROM THE USE OF THIS SPECIFICATION DIAGRAM

NET METERING INTERCONNECTION TO AN EXISTING CT RATED SERVICE
EXAMPLE OF "INFLOW" AND "OUTFLOW" METER ENCLOSURE LAYOUT

Layout 1 – Preferred meter enclosures to be installed side-by-side

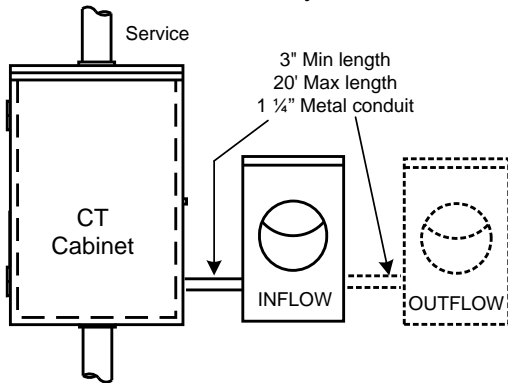

Layout 2

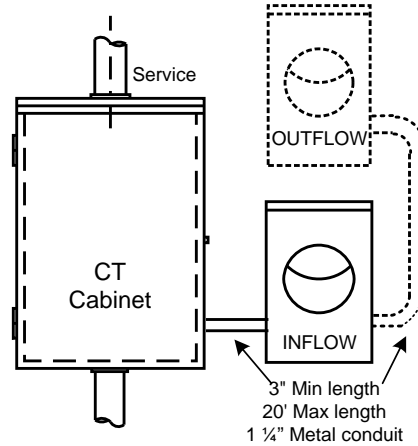

Layout 3

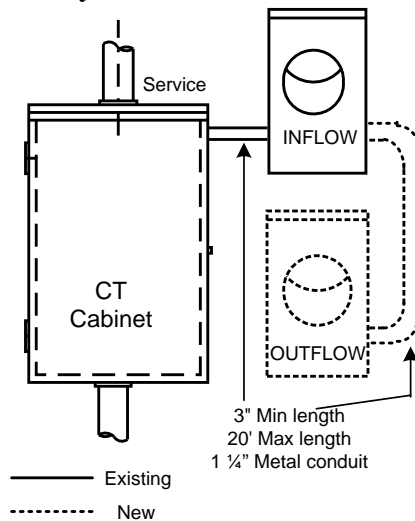

Layout 4 -Approval by Interconnection Team is Required

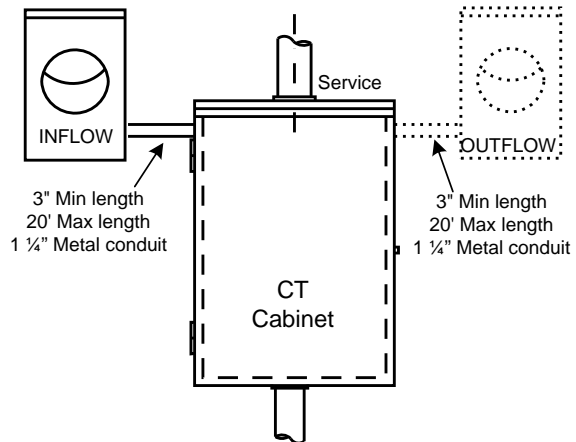

Note 1: Consult with Interconnection Team prior installation at 313-235-4333

Note 2: When the meter enclosures are installed vertically, maximum height is 6' from top of meter enclosure to floor or final grade and minimum of 3'-6" from center of meter face to floor or final grade

Note 3: When the existing meter enclosure is NOT an "S" base, CT rated meter enclosure, customer is responsible to furnish and replace the existing meter enclosure in addition to the "OUTFLOW" meter enclosure.

Note 4: The "INFLOW" and "OUTFLOW" meter enclosures must be "S" base and CT rated. For a complete list of approved meter enclosures, see the Service Installation manual from page 5-8-13

Note 5: Customer is responsible to furnish and install the conduit and meter enclosure. DTE Energy is responsible for providing INFLOW and OUTFLOW meters and the wiring of the CT cabinet to the INFLOW and OUTFLOW Meter

THE DETROIT EDISON COMPANY ASSUMES NO RESPONSIBILITY FOR INJURY OR DAMAGE ARISING FROM THE USE OF THIS SPECIFICATION DIAGRAM

NET METERING INTERCONNECTION TO AN EXISTING METER

EXAMPLE OF THE GENERATION METER CONNECTION

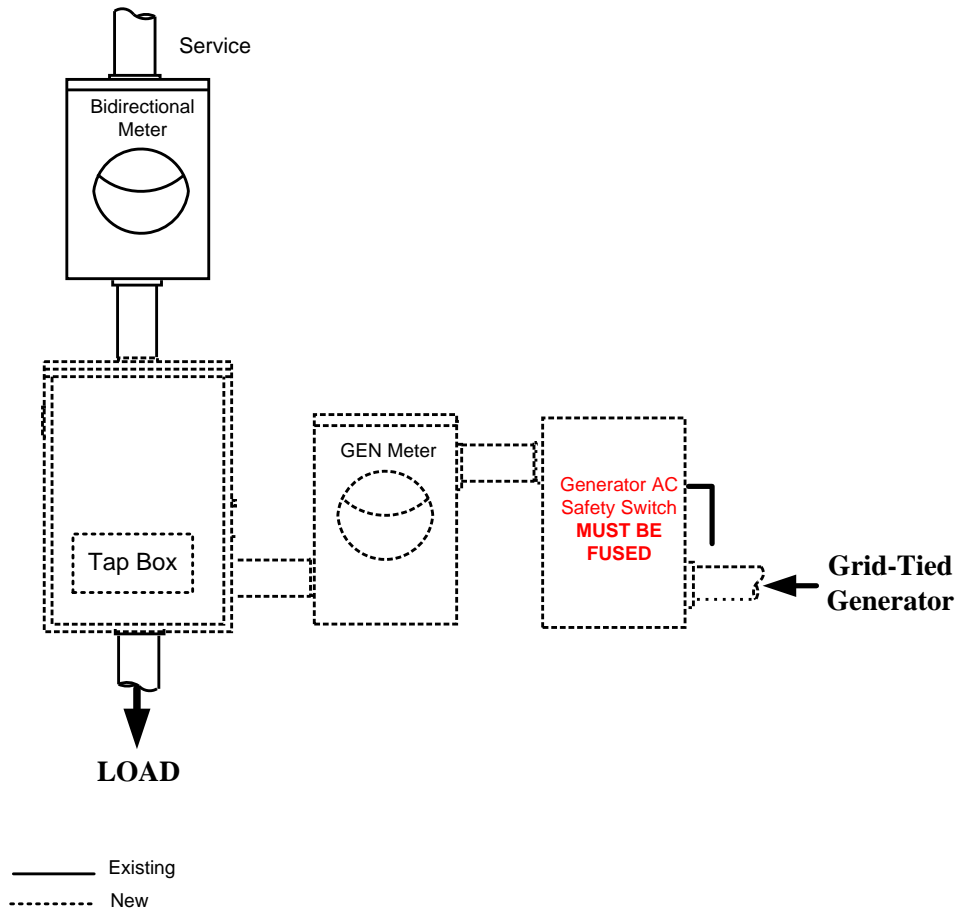

Note 1: Consult with Interconnection Team prior installation at 313-235-4333

Note 2: When the meter enclosures are installed vertically, maximum height is 6' from top of meter enclosure to floor or final grade and minimum of 3'-6" from center of meter face to floor or final grade

Note 3: The conduit between the Generator AC Safety Switch and the GEN could be PVC

Note 4: Isolation between the Neutral and Ground at the Gen Meter Enclosure is REQUIRED

Note 5: Customer is responsible to furnish and install the Disconnect Switches, Gen Meter Enclosure, Tap Box, and conduit. DTE Energy is responsible for providing the GEN Meter

THE DETROIT EDISON COMPANY ASSUMES NO RESPONSIBILITY FOR INJURY OR DAMAGE ARISING FROM THE USE OF THIS SPECIFICATION DIAGRAM

**EXPERIMENTAL SPACE CONDITIONING, WATER HEATING, ELECTRIC
VEHICLE TIME OF DAY SERVICE RATE D1.7**

1. **General**

This rate is available to *residential* customers through special agreement with DTE Energy. For details please consult the Rate Book.

This separately metered rate is approved for permanently installed space conditioning equipment, supplemental permanently hard-wired electric resistance heat and electric water heaters (including tankless).

Space conditioning is defined as a system consisting of one or more electric cooling/heating units (compressors pumping into a condenser and an evaporator with refrigerant and controls to force extraction of heat from one location and dispersion of that heat to another location). The evaporator is in an external duct system that cools or heats the air to be circulated through the space to be conditioned. The condensing coil expels the extracted cold or heated air or water to a location that is not objectionable.

This rate is also available to customers for the sole purpose of charging licensed electric vehicles through a separately metered circuit. Customers taking service under this provision are not subject to the 3,000-customer limitation.

2. **Customer Responsibilities.**

Customer's contractor will supply and install the necessary meter enclosures, wiring and all necessary equipment needed to provide separate metering for this rate. Control equipment such as timers and setback thermostats are also the responsibility of the customer. GFCI protection, conductor sizing and ventilation requirements for electric vehicle charging equipment are also the responsibility of the customer or contractor.

3. **DTE Energy Responsibilities.**

DTE Energy will install the meter when the customer has met the necessary wiring requirements. DTE Energy may convert existing separately metered interruptible installations. The Company will replace the meter or meters with a new time of day meter and remove any radio controls. This can be done where only meter wiring connections are changed. Future removal of unused meter enclosures and interruptible control wiring will be the responsibility of the customer.

4. **Wiring Specifications.**

- (a) The meter enclosure assembly diagrams (7-13-3) for the Residential Time of Day (TOD) Rate D1.7 show typical methods for separate meter installations. In the

case of larger geothermal space conditioning units, a Terminal Box or CT cabinet may be set (see Section 5 (5-3 & 5-4)). Consult a DTE Energy Planner.

- (b) It is the customer's responsibility to furnish the meter enclosure.
- (c) The interconnection between the Residential meter and the TOD meter must be sized to serve the current requirements of the customer's connected load. In any case, the minimum size acceptable is #10 AWG copper or equivalent.
- (d) The contractor will connect the TOD service to the **load** side of the Residential Service meter leaving enough wire slack to easily reach the line terminals. DTE Energy personnel will move the conductors to the **line** side when the installation is accepted for service.

Exceptions to Load Side Connection:

1. Supply of the TOD from a separate service riser or from connection to service conductors in a sealable trough.
 2. Interconnect conductor size #4 AWG and larger will be connected to the line side terminals of the Residential Service meter box by the contractor.
 3. New service that has not been energized.
 4. If the TOD must be interconnected to an interruptible rate meter, the connection will be to the load side of that meter until DTE Energy personnel move that connection to the line side terminals and install the TOD meter.
- (e) Conductor metal must be compatible with the line side conductors, even though the temporary connection will be to the load side (Al to Al or Cu to Cu). When the connection is made to the line and jumpers are installed, DTE Energy will be notified immediately that the installation is unmetered.
 - (f) The TOD service disconnect and distribution panel will be separate from the customer's regular service disconnect and distribution panel.
 - (g) If there are multiple space conductors, water heaters or electric vehicle charging circuits, all such equipment must be fed from the D1.7 TOD Service meter.
 - (h) All wiring must comply with the requirements of the *National Electrical Code*.

EXPERIMENTAL RESIDENTIAL SPACE -CONDITIONING, WATER HEATING,
AND ELECTRIC VEHICLE CHARGING , TIME OF DAY SERVICE RATE D 1.7
METER LAYOUTS AND CONNECTIONS

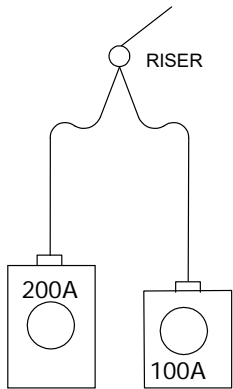

DETAIL A

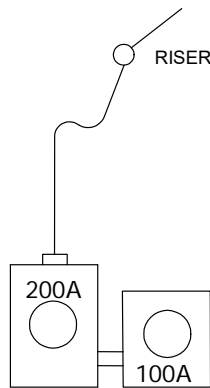

DETAIL B

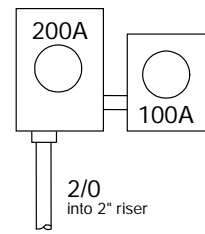

DETAIL C

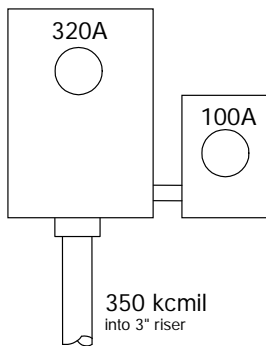

DETAIL D

FOR IDENTIFICATION AND
MAINTENANCE ONLY
NOT FOR NEW INSTALLATION

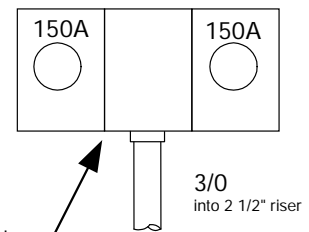

DETAIL E

ED. NO. 731-0073
SECONDARY SERVICE
PEDESTAL FURNISHED
& INSTALLED BY DECO

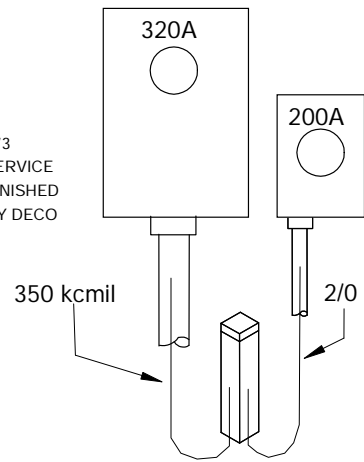

DETAIL G

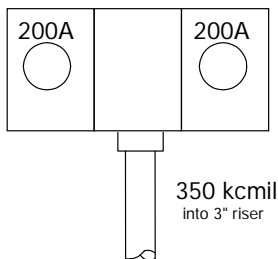

DETAIL F

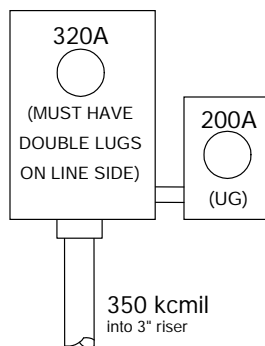

DETAIL H

DTE ENERGY ASSUMES NO RESPONSIBILITY FOR INJURY OR DAMAGE
ARISING FROM THE USE OF THIS SPECIFICATION DIAGRAM

EXPERIMENTAL ELECTRIC VEHICLE RATE D1.9**1. General**

This rate is available to *residential* customers through special agreement with Detroit Edison. For details please consult the Rate Book, Rate Schedule NO. D1.9

This separately metered rate is approved for permanently installed (permanently hard-wired) electric vehicle charging stations.

2. Customer Responsibilities.

The customer must contact Detroit Edison PEV Hotline at 313-235-7700 to apply for Rate D1.9 and **obtain approval prior to start any work.**

Customer's contractor will supply and install the necessary meter enclosures, wiring and all necessary equipment needed to provide separate metering for this rate. Control equipment such as timers is also the responsibility of the customer. GFCI protection, conductor sizing and ventilation requirements for electric vehicle charging equipment are also the responsibility of the customer or contractor.

3. Detroit Edison Responsibilities.

- **Customer Marketing** to approve the customer proposed service change and the metering equipment location and connection (layout and conductor size).
- **Electric Field Operations** will install the meter when the customer has met the necessary wiring requirements and **passed the local electrical inspection.**

4. Wiring Specifications.

- (a) The meter enclosure assembly diagrams (7-14-3) for the Residential Rate D1.9 show typical methods for separate meter installations. For acceptable metering enclosures (single/multiple positions) see ESIG (SIM) section 5-8.
- (b) It is the customer's responsibility to furnish the meter enclosure.
- (c) The interconnection between the Residential meter and the Rate D1.9 meter must be sized to serve the current requirements of the customer's connected load. In any case, the minimum size acceptable is #8 AWG copper or equivalent.
- (d) For **Rate D1.9** the contractor will connect the service to the **load** side of the Residential Service meter leaving enough wire slack to easily reach the line terminals. Detroit Edison personnel will move the conductors to the **line** side when the installation is accepted for service.

Exceptions to Load Side Connection:

1. Supply of the Rate D1.9 from a separate service riser or from connection to service conductors in a sealable trough.
 2. Interconnect conductor size #4 AWG and larger will be connected to the line side terminals of the Residential Service meter box by the contractor.
 3. New service that has not been energized.
 4. If the Rate D1.9 service must be interconnected to an interruptible rate meter, the connection will be to the load side of that meter until Detroit Edison personnel move that connection to the line side terminals and install the meter.
- (e) Conductor metal must be compatible with the line side conductors, even though the temporary connection will be to the load side (Al to Al or Cu to Cu).
- (f) The Rate D1.9 service disconnect and distribution panel will be separate from the customer's regular service disconnect and distribution panel and must comply with the requirements of the *National Electrical Code*.
- (g) If there are multiple space conditioning units, water heaters or electric vehicle charging circuits, Detroit Edison Service Planning will approve the conductor size to properly connect all load to the residential meter.
- (h) All wiring must comply with the requirements of the *National Electrical Code*.
- (i) It is the customer responsibility to contact Detroit Edison Customer Service (800-477-4747) and report that work is being scheduled and the meter enclosure seal will be broken.
When the connection is made to the line side and jumpers are installed, Detroit Edison will be notified immediately that the installation is unmetered.

EXPERIMENTAL ELECTRIC VEHICLE RATE D1.9,

METER LAYOUTS AND CONNECTIONS

The customer must contact Detroit Edison Marketing Dept. to apply for Rate D1.9 and **obtain approval prior to start any work.**

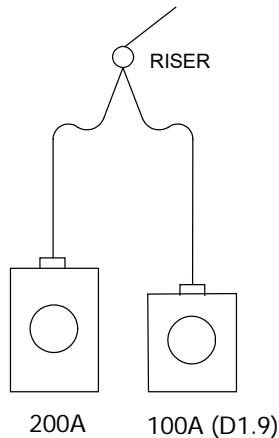
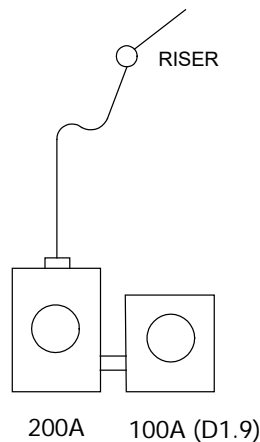
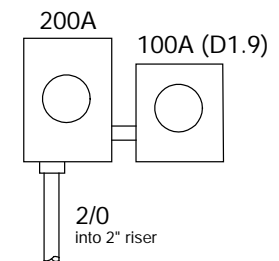
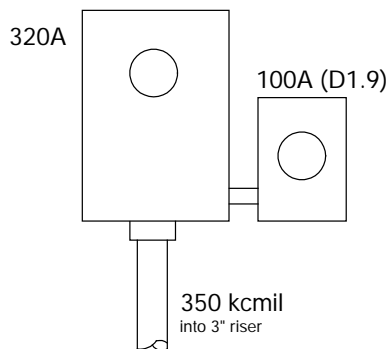
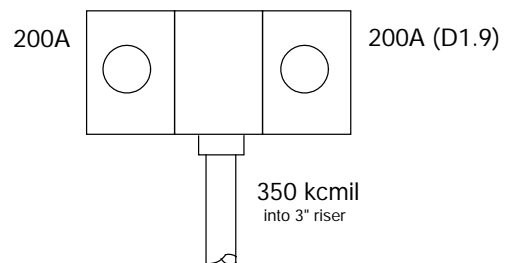
DETAIL ADETAIL BDETAIL CDETAIL DDETAIL E**NOTES:**

1. Detail A: Limited to maximum 3 taps per Service Drop,
2. Details B, C, D, or E: Maximum one additional meter enclosure on each side of Residential meter,
3. All applicable clearances shall apply.
4. D1.9 is available as 200A service for configurations shown above as Details A thru D. Contact Detroit Edison Service Planning to validate Service Drop conductor size and configuration.
5. When two special rate meters are to be connected on the same side of the main meter, obtain approval from Detroit Edison Service Planning. See 3-2-17.

THE DETROIT EDISON COMPANY ASSUMES NO RESPONSIBILITY FOR INJURY OR DAMAGE ARISING FROM THE USE OF THIS SPECIFICATION DIAGRAM.

INTERRUPTIBLE SPACE CONDITIONING SERVICE RATE D1.11. **General**

All customers on Residential Rates D1, D1.2, D1.3, and D2 and all customers on the General Service Rate D3 who have electric central air conditioning and/or central heat pump may opt to have their space conditioning equipment fed from a separate meter. The current registered on this space conditioning meter will be billed at the Interruptible Space Conditioning Service Rate D1.1. Associated equipment, such as condenser fans may also be fed from this meter, but not blowers used for air handling.

2. **Space Conditioning Service Rate Qualifications.**

The following rate qualifications should be checked to be sure that an installation qualifies for the Interruptible Space Conditioning Service Rate:

- (a) The Interruptible Space Conditioning Service Rate (D1.1) is an associated service to be taken with a principal rate. The eligible principal rates are:

- D1 -- Residential Service Rate
- D1.2 -- Residential Time of Day Service Rate
- D1.3 -- Senior Citizen Residential Service Rate
- D2 -- Residential Space Heating Rate
- D3 -- General Service Rate

The D1.1 associated service is not available with any other rates.

- (b) If there is a multiple heat pump/air conditioner installation or a combination of heat pump(s) and air conditioner(s) for single meter occupancy, all units must be on the space conditioning meter.
- (c) All equipment fed through the space conditioning meter except the 24 volt power source for the DECo radio control unit (RCU) must be interrupted when the RCU is signaled.
- (d) Only installations feeding ducted air distribution qualify. Specifically, window units or unducted through the wall units are not allowed on this rate.
- (e) Only the compressor and directly associated equipment may be fed through the space-conditioning meter. Specifically, condenser fans can be fed through the space-conditioning meter, but indoor air movement fans (blowers) that move air for heating and cooling cannot. **EXCEPTION:** Fans on integrated package units or fans used to move conditioned air from both the air conditioner(s) and heat pump(s) and not used to move air from any other alternate heating or cooling source. Also, water source heat pump water pumps may be fed through the space-conditioning meter. **All equipment fed from the space-conditioning meter must interrupt when the RCU is signaled.**

The above points are provided as a checklist for installation under consideration.

3. **Customer Responsibilities.**

To be eligible for the space-conditioning rate, the customer or contractor is responsible for supplying and installing the meter enclosures, also an enclosure that is suitable for use outdoors (AC-10), NEMA 3R, equipment, wiring and for making circuit modifications necessary to separately meter and control the space conditioning equipment. The requirements are shown in subsection 7-15. They include:

- (a) An uninterrupted 24-volt source for the Radio Control Unit (RCU) which will supply a minimum 8 VA for the RCU in addition to any additional customer load. This 24-volt circuit must be identified by the installer in the AC-10 for the Detroit Edison field person.
- (b) A single loop in series with the compressor start circuit(s) that, when opened, will open the compressor start circuit(s) to all space conditioning units fed from the space conditioning meter.
- (c) On multiple units or a combination of heat pump and air conditioning units, an interconnect relay(s) will be required to avoid cross connecting of control circuits. If simultaneous starting of compressors could cause excessive flicker or voltage drop, a delay scheme must be applied. Such equipment will be furnished and installed by the customer or contractor.
- (d) Separate circuitry, switches, meter enclosures, an enclosure suitable for outdoor use (AC-10), etc. which may be necessary to isolate the equipment fed from the space conditioning meter from all other loads fed from other meters.

4. **Detroit Edison Responsibilities.**

Detroit Edison will supply and install the RCU when the wiring requirements have been completed. **The customer or contractor is responsible for installing the equipment and circuitry required for the separate metering and control of the space conditioning equipment.**

EQUIPMENT ASSEMBLY FOR INTERRUPTIBLE SPACE CONDITIONING RATED 1.1

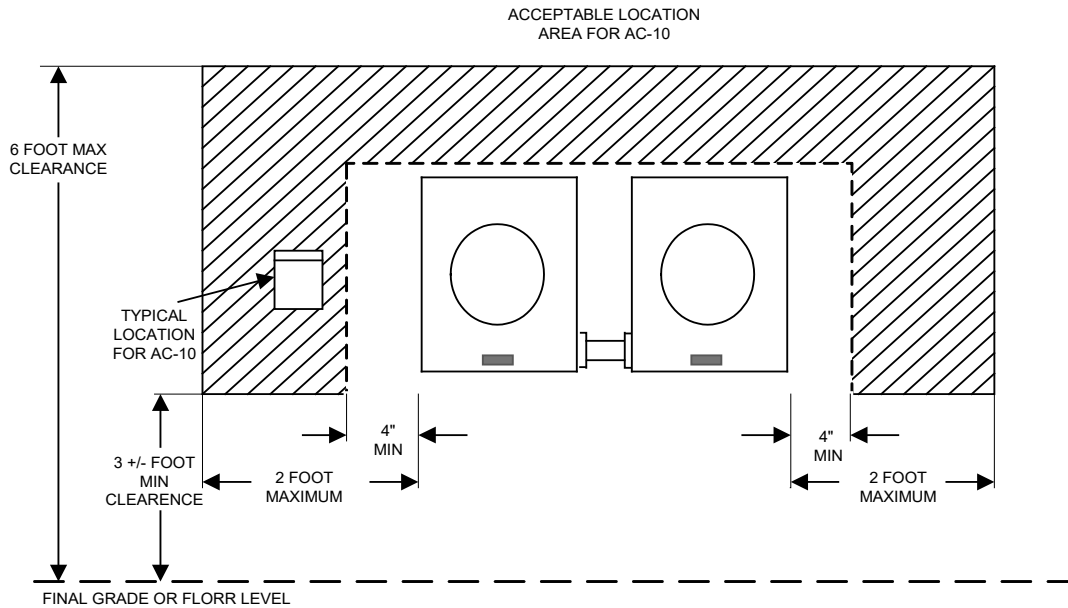
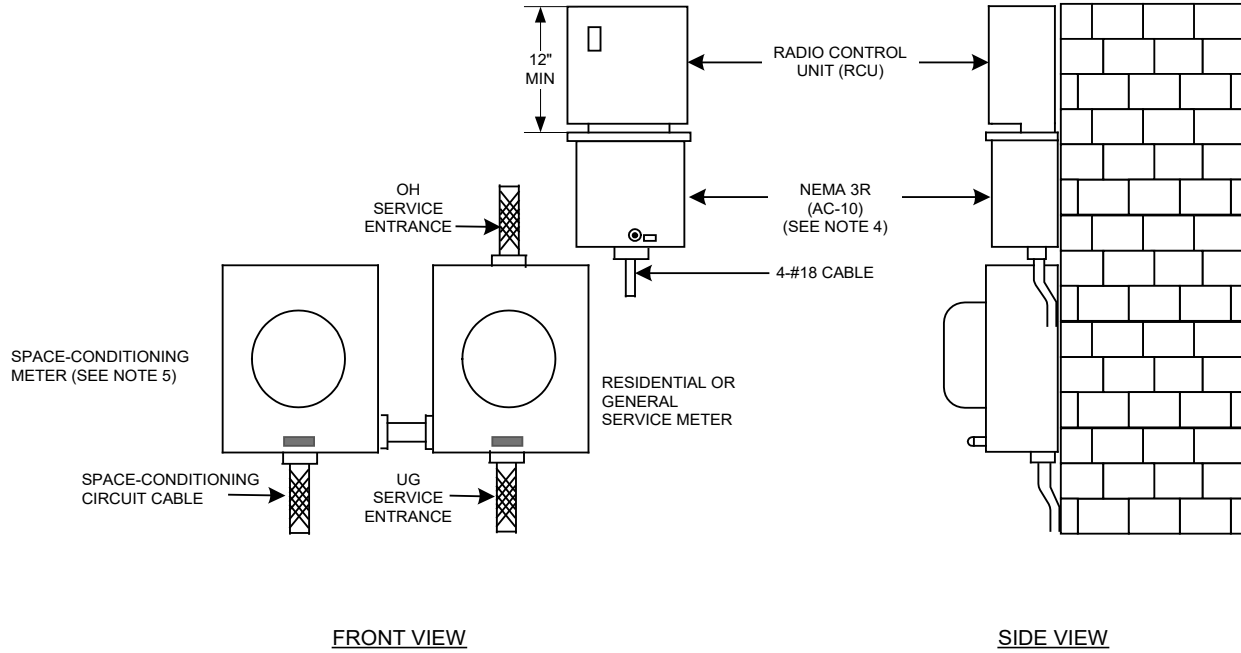

REFER TO NOTES ON PAGES 7-15-6 & 7

THE DETROIT EDISON COMPANY ASSUMES NO RESPONSIBILITY FOR INJURY OR DAMAGE ARISING FROM THE USE OF THIS SPECIFICATION DIAGRAM.

SCHEMATIC FOR WIRING CIRCUIT FOR THE INTERRUPTIBLE SPACE-CONDITION SERVICE RATE D1.1 SINGLE CUSTOMER WITH SINGLE SPACE-CONDITIONING UNIT

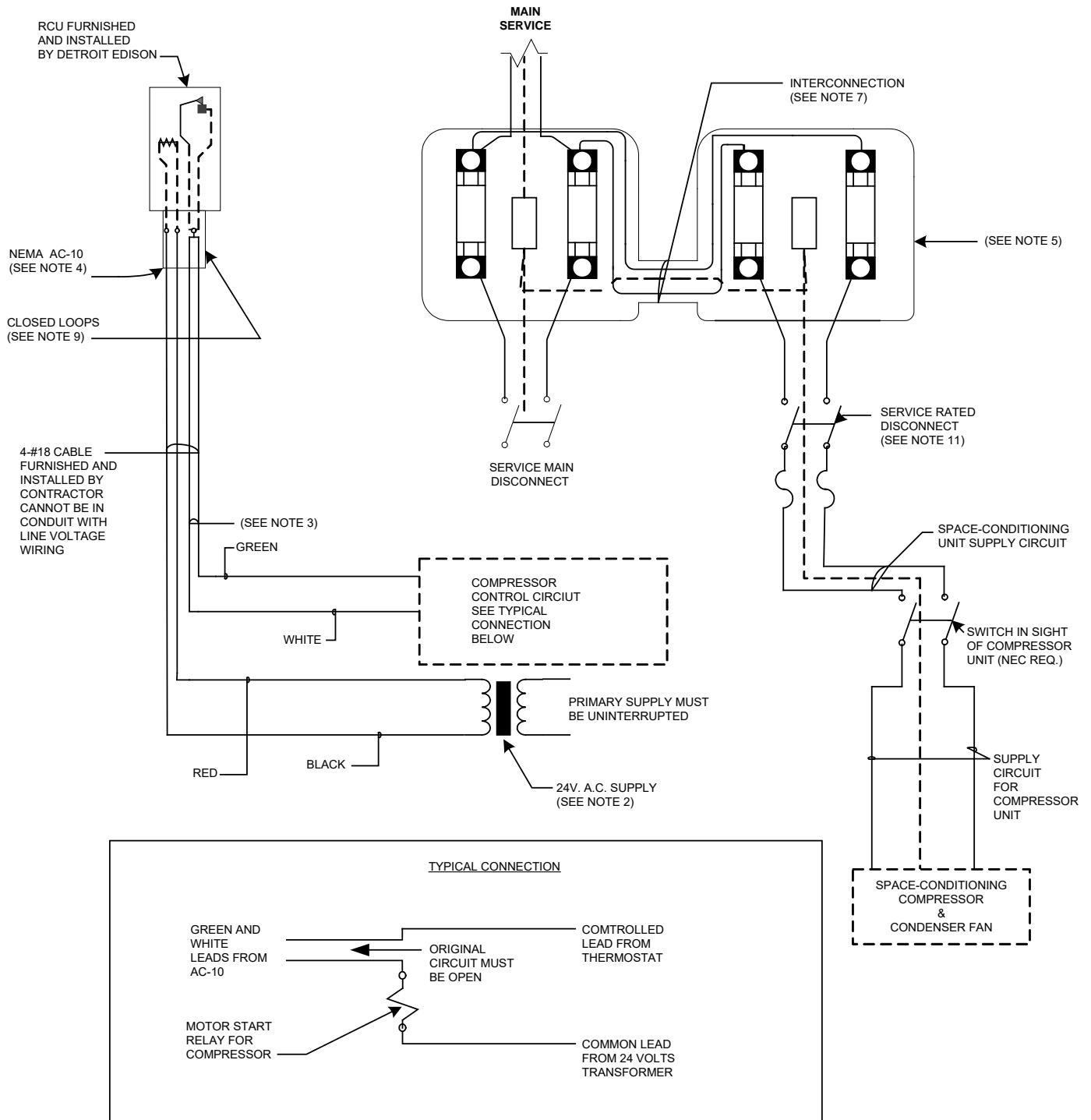

REFER TO NOTES ON PAGES 7-15-6 & 7

THE DETROIT EDISON COMPANY ASSUMES NO RESPONSIBILITY FOR INJURY OR DAMAGE ARISING FROM THE USE OF THIS SPECIFICATION DIAGRAM.

APPLICATION OF TYPICAL RESIDENTIAL INTERRUPTIBLE SPACE-CONDITIONING SEPARATELY METERED SERVICE RATE D1.1

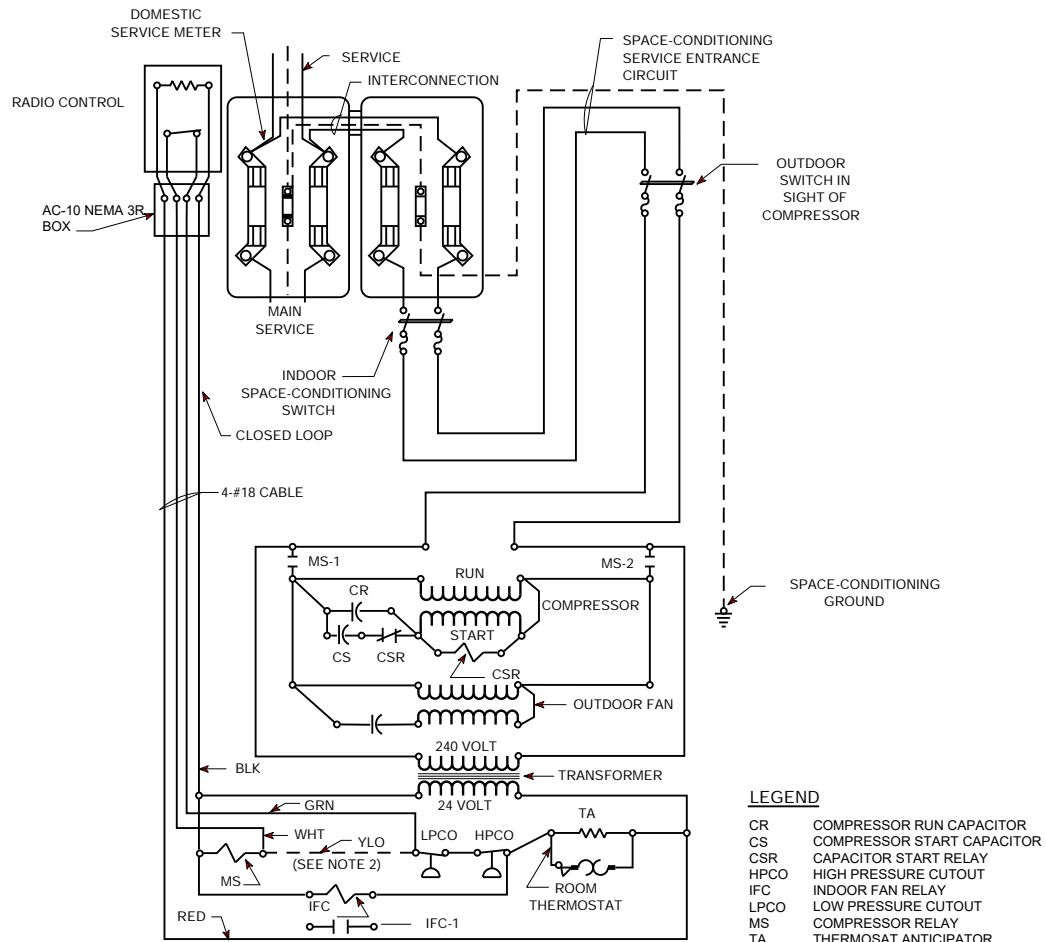

ALL RELAY CONTACTS SHOWN IN THE DE-ENERGIZED POSITION

NOTES:

1. THE APPLICATION SCHEMATIC SHOW THE CIRCUIT TO QUALIFY AN INSTALLATION FOR THE INTERRUPTIBLE SPACE-CONDITIONING RATE D1.1. THE CONTROL CIRCUIT IS SHOWN APPLIED TO A TYPICAL SPACE-CONDITIONING CIRCUIT. BECAUSE OF THE LARGE NUMBER OF MODEL NUMBERS OF UNITS PRODUCED BY VARIOUS MANUFACTURERS OF SPACE-CONDITIONING EQUIPMENT, IT IS IMPRACTICAL TO DETAIL SPECIFIC RECOMMENDATIONS AS TO THE 'CONTROL POINT' OF EACH SPACE-CONDITIONING UNIT. THESE SPECIFICATIONS PROVIDE GUIDELINES, BUT IT IS THE INSTALLER'S RESPONSIBILITY TO CAREFULLY REVIEW EACH UNIT'S CONTROL CIRCUIT AND SELECT THE CONTROL POINT WHICH WILL PROPERLY CONTROL THE COMPRESSOR ON DECO RCU INTERRUPT OPERATION. THEREFORE, **THIS SCHEMATIC IS INTENDED AS A GUIDE** FOR ADAPTING THESE CIRCUITS. SEE OTHER PAGES IN THIS SECTION FOR INSTALLATION SPECIFICATIONS.
2. DOTTED LINE SHOWS THE ORIGINAL CIRCUIT ROUTE.
3. RADIO CONTROL UNIT (RCU) WILL BE FURNISHED AND INSTALLED BY DECO.

THE DETROIT EDISON COMPANY ASSUMES NO RESPONSIBILITY FOR INJURY OR DAMAGE ARISING FROM THE USE OF THIS SPECIFICATION DIAGRAM.

NOTES TO INTERRUPTIBLE SPACE CONDITIONING D1.1
SCHEMATIC AND EQUIPMENT ASSEMBLY
SINGLE OCCUPANCY BUILDING

1. The application schematic shows a typical circuit to qualify an installation for the Interruptible Space Conditioning Service Rate D1.1. The remote control loop must interrupt the compressor start contactor or the control loop of the motor start circuit. All space conditioning equipment modifications and approvals for use will be the contractor's responsibility.
2. The 24 volt transformer must be capable of supplying an *additional* 8 VA for the RCU. This transformer may also feed the compressor control circuit. If this control circuit is not 24 volts, consult the Planner or Meter Engineering. See 2005 NEC 250.30 (A)(1) Exception No. 3 and (A)(3) Exception No. 3 for grounding.
3. This connection must open the compressor start control circuit to all compressors fed from the space conditioning meter. Multiple units must be wired to avoid simultaneous starting if this could cause excessive flicker. Separate control circuits must be isolated from each other on separate relay contacts.
4. The NEMA 3R enclosure (AC-10), with knockouts will be furnished and installed by the customer's contractor. It must be located within the dimensions of the acceptable area and on the same wall. Wires may enter from the bottom or back. The top or side must remain clear for the RCU mounting. The top of the AC-10 is the preferred RCU location. See SIM-ESIG Page 7-15-3.
5. The meter enclosure will be furnished and installed by the contractor. For installations requiring more than 100 Amps or a three-phase service, consult with Planning & Design. For installations greater than 320 amps single-phase or 200 Amps three-phase, a suitable CT cabinet will be furnished and installed by the contractor.
6. If the line side conductor is a different metal from the load side, the contractor must use an enclosure with two neutral setscrews or a double neutral kit.
7. The interconnection between the Residential or General Service meter and the Space Conditioning meter will be sized according to the current requirements of the customer's space conditioner. Where conductors meet in a terminal, they must be the same metal; that is, copper to copper or aluminum to aluminum. In all cases, the minimum size allowed is #10 AWG copper or equivalent. Flexible metal conduit is not allowed between the enclosures. See Electrical Code Rules Part 8, Bureau of Construction Codes; R 408.30867 & 8.

NOTES TO INTERRUPTIBLE SPACE CONDITIONING D1.1
SINGLE OCCUPANCY BUILDING (Cont.)

8. The contactor will connect the space conditioning service to the load side of the Residential, or General Service meter leaving enough slack to easily reach the line terminals. Detroit Edison personnel will move the conductors to the line side when the installation is put in service. Conductor metal **MUST** be compatible with the line side conductors.
Exceptions to load side connection:
 - (a) The supply to the space-conditioning meter is taken from a second riser to a multiple tapped overhead service drop.
 - (b) The service riser is routed into a sealable trough with separate taps for the Residential or General Service meter and the space-conditioning meter.
 - (c) The service is not energized.
 - (d) The interconnection conductors are #4 AWG or larger.
9. The contractor must wire nut the compressor circuit leads and insulate the ends of the 24-volt transformer leads in the AC-10. All circuits must be tagged and identified in the AC-10. The contractor must leave a minimum of 6 inches of free wire for the DECo RCU connection.
10. Upon completion of the work, the contractor must ensure that the space conditioning equipment will operate properly and notify DECo, giving the name(s), address(es) and telephone number(s) of the customer(s).
11. The space conditioning disconnect switch will be separate form the customer's main and branch panel. There will be no unused main or branch circuit poles or the facility to install additional devices other than those needed for the space conditioning service.
12. On water source heat pumps, when the compressor and water pump are fed from the space conditioning meter, the RCU will interrupt both the compressor and the water pump circuit. The contractor will be responsible for consulting with the manufacturer for correct wiring modifications. The water pump must supply water only to the heat pump in order to be wired to the space-conditioning meter.
13. The AC-10 enclosure (NEMA 3R), if metallic must be bonded to comply with 2005 NFPA 70, Article 250 (A), (1), Exception No. 3 [ground wire size] & (3), Exception No. 3 [Grounding Electrode Conductor]. See 250.20 (A).
A nonmetallic enclosure will not require bonding.
14. All wiring must comply with the requirements of the current *NFPA 70 and applicable State Building Code*.

NOTES TO INTERRUPTIBLE SPACE-CONDITIONING (D1.1)
SINGLE OCCUPANCY BUILDING (Cont.)

THE FOLLOWING NOTES APPLY TO MULTIPLE SPACE CONDITIONING UNITS:

15. The control circuits of multiple unit air conditioner and/or heat pump systems must be electrically isolated from each other to prevent circuit interaction problems. The 2005 National Electrical Code article 725-41(b) addresses this problem. Therefore, since the RCU has a single pole contact, a pilot relay will be necessary with an isolated contact for each unit if circuit separation is necessary. Compliance with this requirement is the responsibility of the contractor.
16. If simultaneous start will cause a flicker problem, separate time delay relays with five second delay between starts will be necessary. This will also accomplish control circuit isolation. Simultaneous start multiple compressor units is permissible, providing total locked rotor current does not exceed 150 amps at 240 volts single-phase.
17. All relays used for controlling must be normally open, held closed for unit operation. These relays will be furnished and installed in sealable enclosures by the customer's contractor. Relays must be located as close to the meter as practical. Indoor location is acceptable but undesirable. The relay is not to be mounted in the AC-10.
18. Schematic shows relay coils connected in parallel with staggered time delay for each set of coils: i.e., coils #1 and #2 - delay, coils #3 and #4 - five second delay, etc.
19. Only one space-conditioning RCU will be assigned to a single occupancy building.

The Detroit Edison Company assumes no responsibility for injury or damages arising from the use of these specifications.

EQUIPMENT ASSEMBLY FOR COMMERCIAL INTERRUPTIBLE SPACE-CONDITIONING SERVICE RATE D1.1

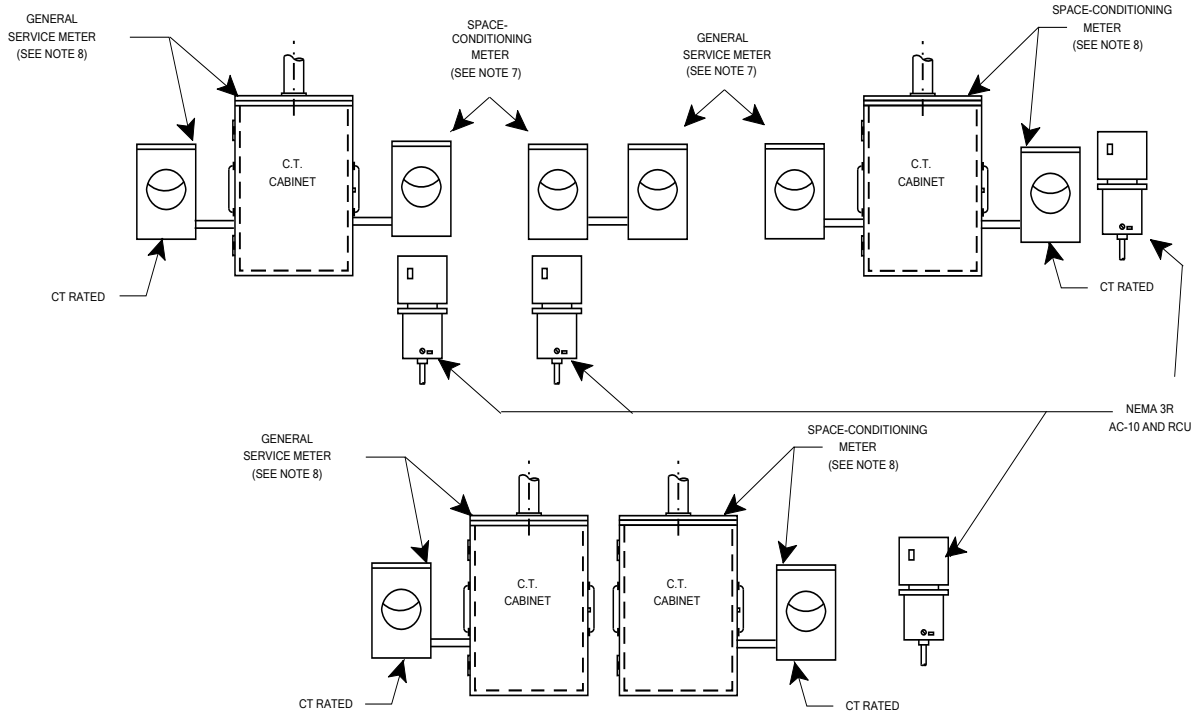

EQUIPMENT ASSEMBLY COMBINATIONS

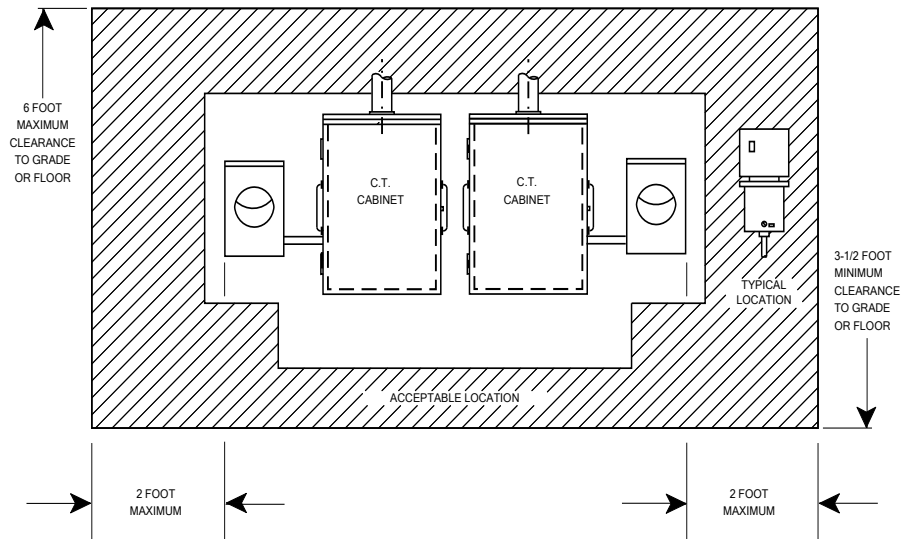

NEMA 3R (AC-10) LOCATION GUIDE

REFER TO NOTES ON PAGE 7-15-11

DTE ENERGY ASSUMES NO RESPONSIBILITY FOR INJURY OR DAMAGE ARISING FROM THE USE OF THIS SPECIFICATION DIAGRAM.

NOTES TO INTERRUPTIBLE SPACE-CONDITIONING (D1.1)
COMMERCIAL APPLICATIONS

1. The equipment assembly drawing shows the possible combinations of meter and control equipment. Current transformer (CT) cabinets are shown for services in excess of 200 amps, however, the CT cabinet (compartment) could be in switchboards.
2. An example of a space-conditioner with a control circuit is not shown because of the many variations in commercial control circuits.
3. The customer's contractor will bring a 4 wire circuit to the AC-10 NEMA 3R enclosure. Two of the conductors will furnish uninterrupted 24 volts AC at 8 volt-amps. The other two wires are for interruption control through a normally closed isolated contact in the radio control unit (RCU). The RCU relay is capable of interrupting at 60 Hz. 3 amperes at 24 volts Resistive Load. The customer's control circuit must cause the compressor(s) to go off line when the RCU control circuits open. The RCU will be furnished and installed by DECo.
4. The RCU must be capable of interrupting all space-conditioning equipment in all of its phases of operation. **All equipment fed from the space-conditioning meter must stop.**
5. The NEMA 3R enclosure (AC-10) will be furnished and installed by the customer's contractor. It must be located within the dimensions of the acceptable area and on the same wall. Wires may enter from the bottom or back. The top or side must remain clear for the RCU mounting. The top of the AC-10 is the preferred RCU location. The RCU preferred location is outdoors. It may be located on an outside wall.
6. The space-conditioning meter enclosure for self-contained meters (up to 200 amps) will be furnished and installed by the customer's contractor.
7. The CT cabinet or switchboard section for space-conditioning service over 200 amps will be furnished and installed by the customer's contractor. The meter enclosure will be furnished and installed by the customer's contractor.
8. The customer's contractor must wire nut the compressor circuit leads and insulate the ends of the 24 volt transformer leads in the AC-10. All circuits must be tagged and identified in the AC-10. The contractor must leave a minimum of 6 inches of free wire for the DECo RCU connection.
9. The contractor must ensure that the space-conditioning equipment will operate properly and also must notify DECo, giving the name(s), address(es), and telephone number(s) of the customer(s).

10. On multiple installations, delay circuits may have to be added to the customer's control circuit by his contractor if simultaneous start at the end of a DECo interruption caused objectionable flicker. The contractor will furnish the relays and a sealable enclosure for the relays. The relays may not be mounted in the AC-10.
11. The metallic enclosure (AC-10) must be bonded to comply with 2005 NFPA 70 (National Electrical Code), Article 250.30 Grounding Separately Derived Alternating Current Systems, (1) System Bonding Jumper, Exception No. 3 for size of jumper, also(3) Grounding Electrode Conductor, Single Separately Derived System, Exception No. 3, "*Not required for a transformer rated not more than 1000 volt-amperes, provided the grounded conductor is bonded to the transformer frame or enclosure by a jumper sized in accordance with 250.30(A)(1), Exception No. 3, and transformer frame or enclosure is grounded by one the means specified in 250.134.*" See also 2005 NFPA 70, 250.20 Alternating-Current Systems to Be Grounded, (A) Alternating-Current Systems of Less Than 50 Volts, *Grounding of the transformer secondary is not required If the transformer is supplied 150 Volts to ground or less, if supply side is grounded and does not go overhead outside of the buildings. **A nonmetallic enclosure will not require bonding.***
12. All wiring must comply with the current *National Electrical Code*.

The Detroit Edison Company assumes no responsibility for the injury or damages arising from the use of these specifications.

NOTES TO INTERRUPTIBLE SPACE CONDITIONING D1.1
SCHEMATIC AND EQUIPMENT ASSEMBLY
MULTIPLE OCCUPANCY BUILDING

1. The application schematic shows a typical circuit to qualify an installation in a multiple occupancy building so that tenants may go on the Interruptible Space Conditioning rate D1.1. The remote control loop must interrupt the compressor start contactor or the control loop of the motor start circuit. The customer's contractor is responsible for all space conditioner equipment modifications and approvals for use.
2. The 24 volt transformer must be capable of supplying 20 volt amperes (VA). The transformer primary will be fed from the house circuit. If the building does not have a house meter, consult Planning and Design. Under these circumstances, it may be necessary to use a Radio Control Unit (RCU) for each tenant and wire according to the single residence installation instructions.
3. Each cable from a tenant control circuit will be controlled by an isolated dry contact. The Planner will determine the number of relays according to whether some of the space conditioners can be started simultaneously. This will be determined from flicker calculations. If more than six relays are needed, more than one relay cabinet will be required. This will increase the load on the 24 volt transformer by another 20 volt amperes (VA) per relay cabinet.
4. The contractor is responsible for the design and installation of any all devices used to turn any space conditioning circuits on or off. They are also responsible for correctly interfacing with the DECO RCU.
5. All cables entering the cabinet should be #18 AWG minimum. If cables larger than #12 AWG must be used, consult Planning and Design.
6. As each tenant control cable is brought into the relay cabinet, the contractor will wire nut the two leads together to give the tenant temporary service until the RCU is installed. The contractor will also identify the cables with marker tags shipped with the relay cabinet and enter the tag number and corresponding apartment number in the register on the cabinet cover. RCU will control ALL relay contacts. See SIM-ESIG Page 7-15-8 for RCU to relay interfacing.
7. The Interruptible Space Conditioning (ISC) meter must be vertically or horizontally adjacent to the tenant's Residential meter or the General Service meter. If this is a problem on an existing building converting to ISC, consult Design Practices.
8. Allow 1-foot clearance above relay panels for installation of the Radio Control Unit (RCU).

NOTES TO INTERRUPTIBLE SPACE CONDITIONING D1.1
MULTIPLE OCCUPANCY BUILDING (Cont.)

9. DECo personnel will install the Radio Control Unit (RCU).
10. The contractor must ensure that the space conditioner will operate after the work is complete.
11. The space conditioners must be operated before the DECo representative leaves the job. This will require coordination with the customer for access to the individual tenant thermostats.
12. All relay cabinets must be properly bonded and grounded in compliance with NFPA 70 (NEC), Articles 200 and 250.

SPECIAL CASES:

Changing existing buildings to qualify for the ISC Rate.

13. Contact the DECo Planner who will consult Planning and Design. Special arrangements will be considered to retrofit such buildings depending on the circumstances in each case. Where the original meter equipment is the *Superior* 4, 5 or 6 high stacks, Planning and Design will advise the electrical contractor on the method of feeding the added ISC meters. Contractors will **not** modify DECo metering equipment for this or any other purpose.
14. If one tenant in a multiple occupancy building proposes to have the unit metering and control circuit changed to qualify for the ISC Rate, the building owner or condominium association must agree to such a change. It must be further understood that single installations may have to be modified if, at a later date, the entire building is converted to ISC.

The Detroit Edison Company assumes no responsibility for the injury or damages arising from the use of these specifications.

INTERRUPTIBLE SPACE-CONDITIONING RATE D1.1
SCHEMATIC AND EQUIPMENT ASSEMBLY
MULTIPLE OCCUPANCY BUILDING

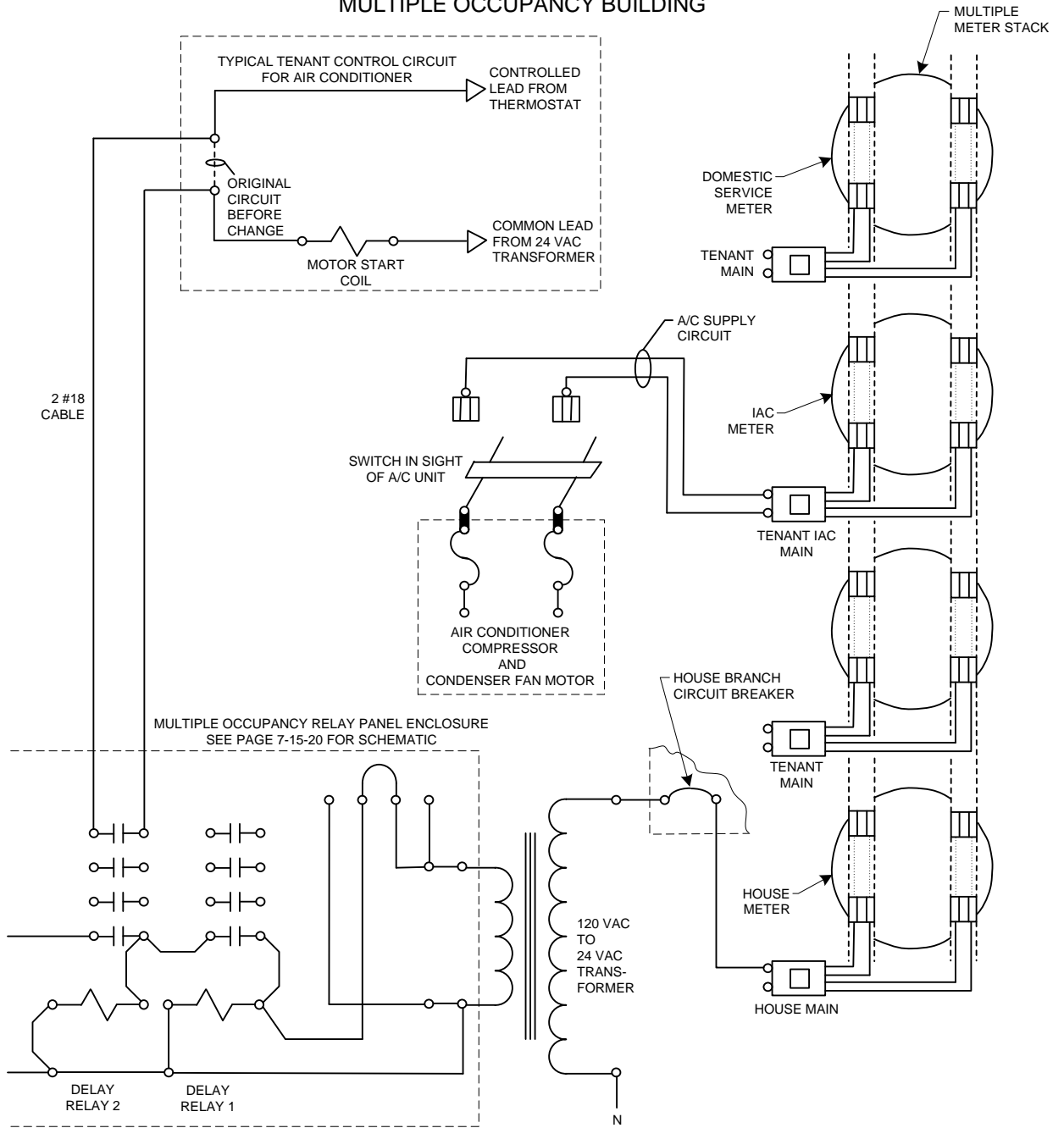

NOTES:

1. ALL RELAY CONTACTS SHOWN IN DE-ENERGIZED POSITIONS.
2. TWO RELAYS SHOWN IN SCHEMATIC. RELAY PANEL MAY HAVE UP TO SIX.

THE DETROIT EDISON COMPANY ASSUMES NO RESPONSIBILITY FOR INJURY OR DAMAGE ARISING FROM THE USE OF THIS SPECIFICATION DIAGRAM.

INTERRUPTIBLE SPACE-CONDITIONING D1.1
SCHEMATIC AND EQUIPMENT ASSEMBLY
MULTIPLE OCCUPANCY BUILDING

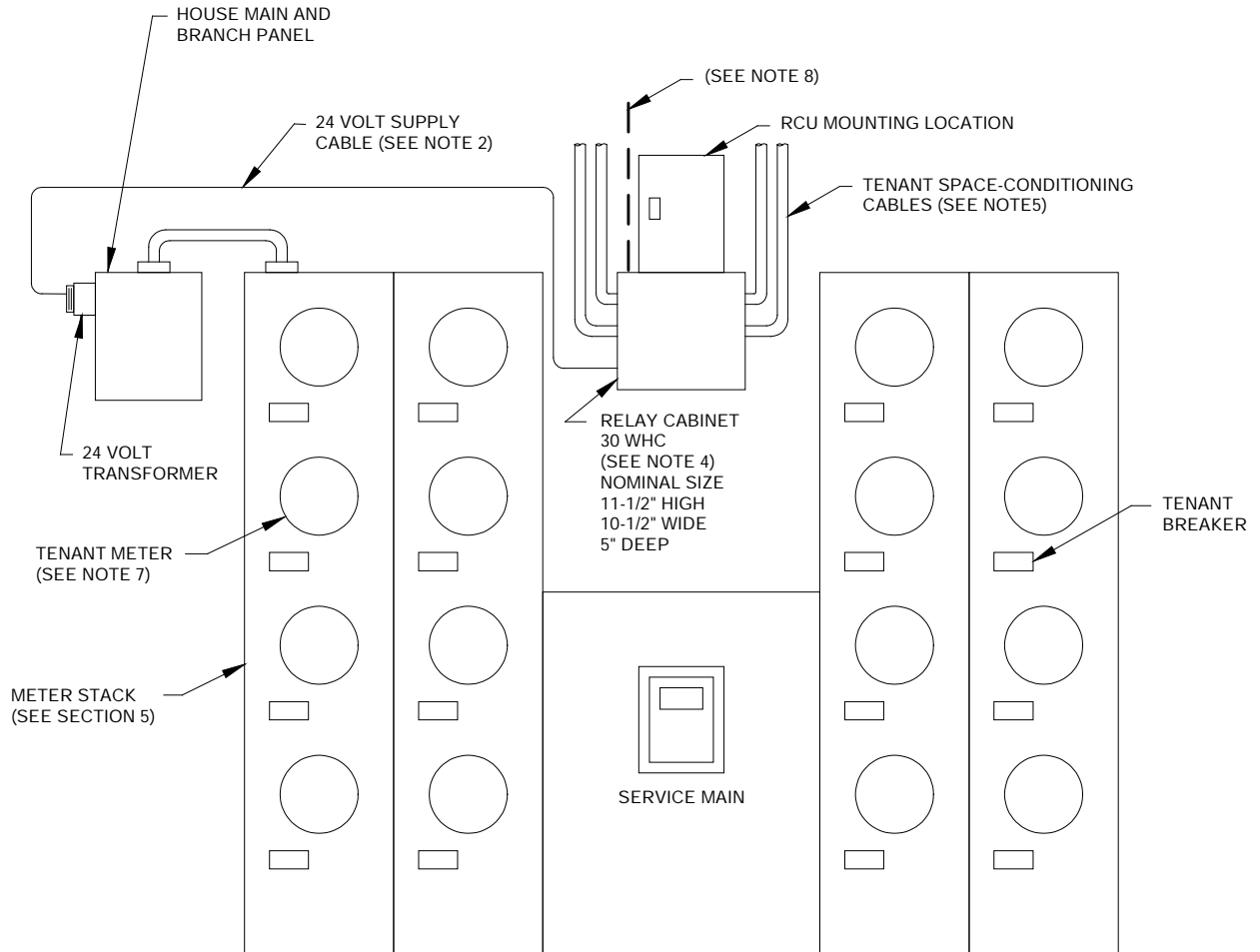

THE DETROIT EDISON COMPANY ASSUMES NO RESPONSIBILITY FOR INJURY OR DAMAGE ARISING FROM THE USE OF THIS SPECIFICATION DIAGRAM.

INTERRUPTIBLE AIR CONDITIONING D1.1 ALTERNATE CIRCUIT

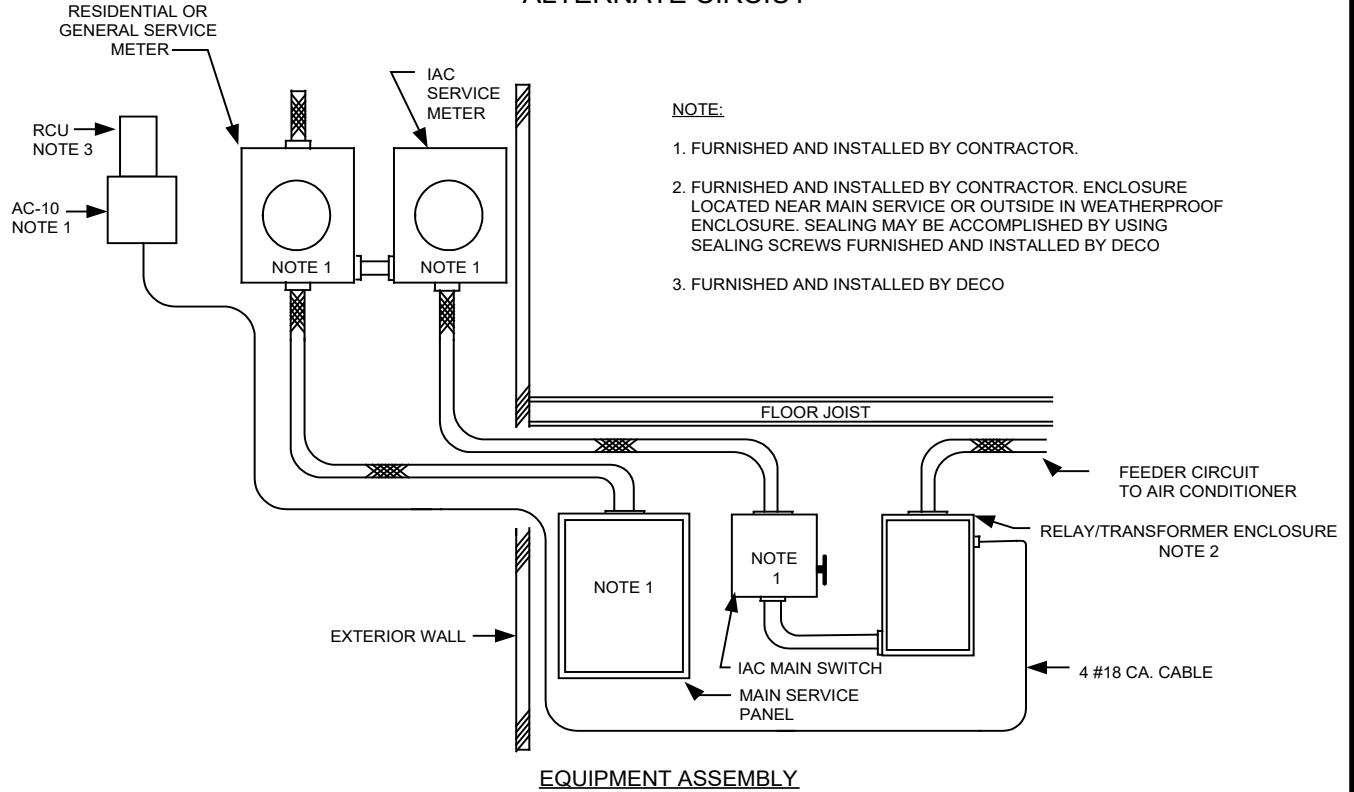

- NOTE:**
1. FURNISHED AND INSTALLED BY CONTRACTOR.
 2. FURNISHED AND INSTALLED BY CONTRACTOR. ENCLOSURE LOCATED NEAR MAIN SERVICE OR OUTSIDE IN WEATHERPROOF ENCLOSURE. SEALING MAY BE ACCOMPLISHED BY USING SEALING SCREWS FURNISHED AND INSTALLED BY DECO
 3. FURNISHED AND INSTALLED BY DECO

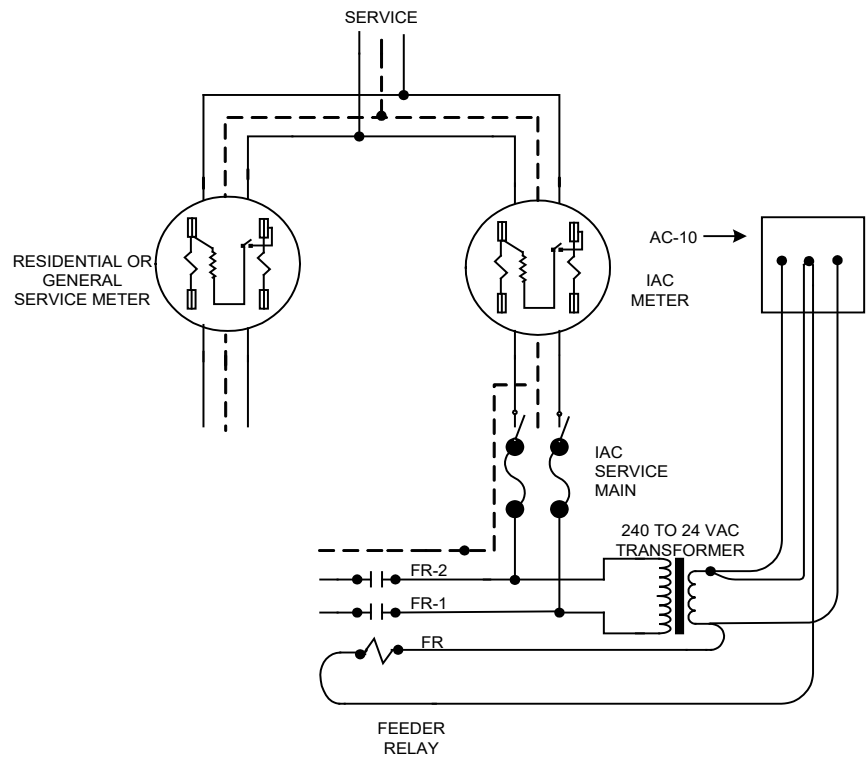

WIRING SCHEMATIC

MOBILE AND MANUFACTURED HOME PEDESTAL EQUIPMENT ASSEMBLY
FOR INTERRUPTIBLE AIR CONDITIONING
(IAC) RATE D1.1

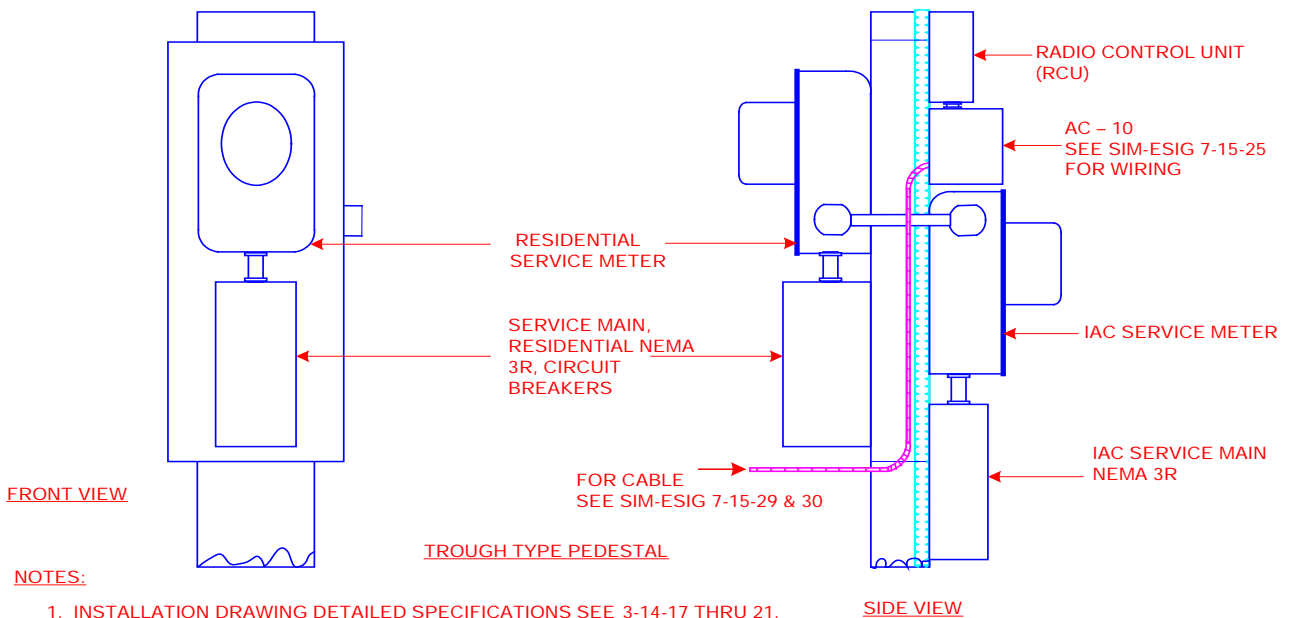
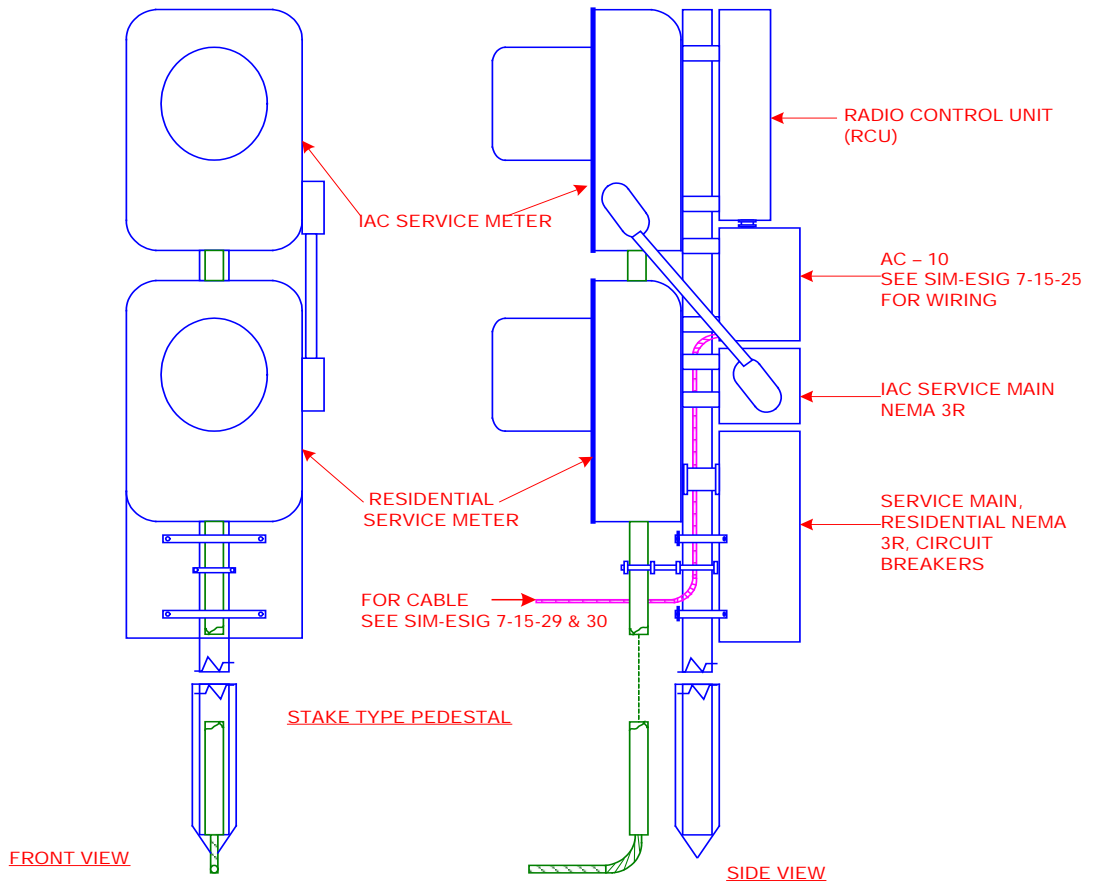

NOTES:

1. INSTALLATION DRAWING DETAILED SPECIFICATIONS SEE 3-14-17 THRU 21.
2. CONTRACTOR TO FURNISH METER ENCLOSURES.
3. GROUNDING MUST COMPLY WITH ALL NFPA 70 REQUIREMENTS.

THE DETROIT EDISON COMPANY ASSUMES NO RESPONSIBILITY FOR INJURY OR DAMAGE ARISING FROM THE USE OF THIS SPECIFICATION DIAGRAM.

MOBILE AND MANUFACTURED HOME MAST OR SERVICE POLE EQUIPMENT ASSEMBLY
FOR INTERRUPTIBLE AIR CONDITIONING
(IAC) RATE D1.1

MAST

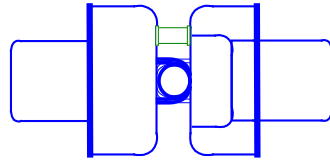

TOP VIEW

SERVICE POLE - FOR MAINTENANCE ONLY

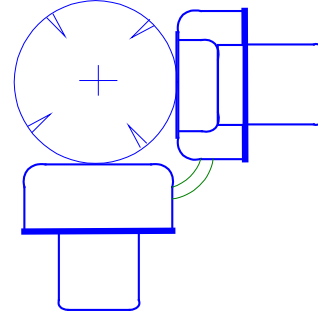

TOP VIEW

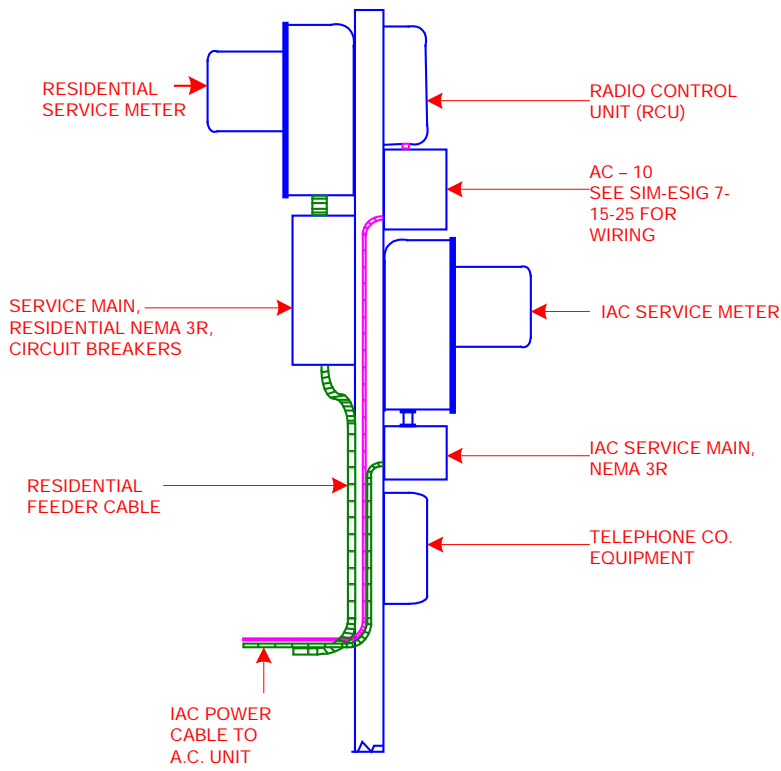

SIDE VIEW

MAST

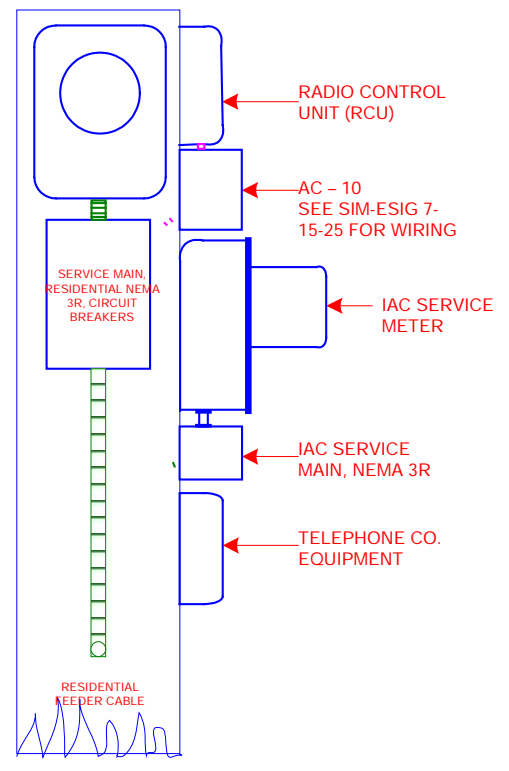

FRONT VIEW

SERVICE POLE - FOR MAINTENANCE ONLY

NOTES:

1. INSTALLATION DRAWING DETAILED SPECIFICATIONS SEE 3-14-17 THRU 21
2. CONTRACTOR TO FURNISH METER ENCLOSURES.
3. GROUNDING MUST COMPLY WITH ALL NFPA 70 REQUIREMENTS.

THE DETROIT EDISON COMPANY ASSUMES NO RESPONSIBILITY FOR INJURY OR DAMAGE ARISING FROM THE USE OF THIS SPECIFICATION DIAGRAM.

MOBILE AND MANUFACTURED HOME PEDESTAL EQUIPMENT ASSEMBLY FOR INTERRUPTIBLE AIR CONDITIONING (IAC) RATE D1.1 IN COMBINATION WITH WATER HEATER RATE D-5

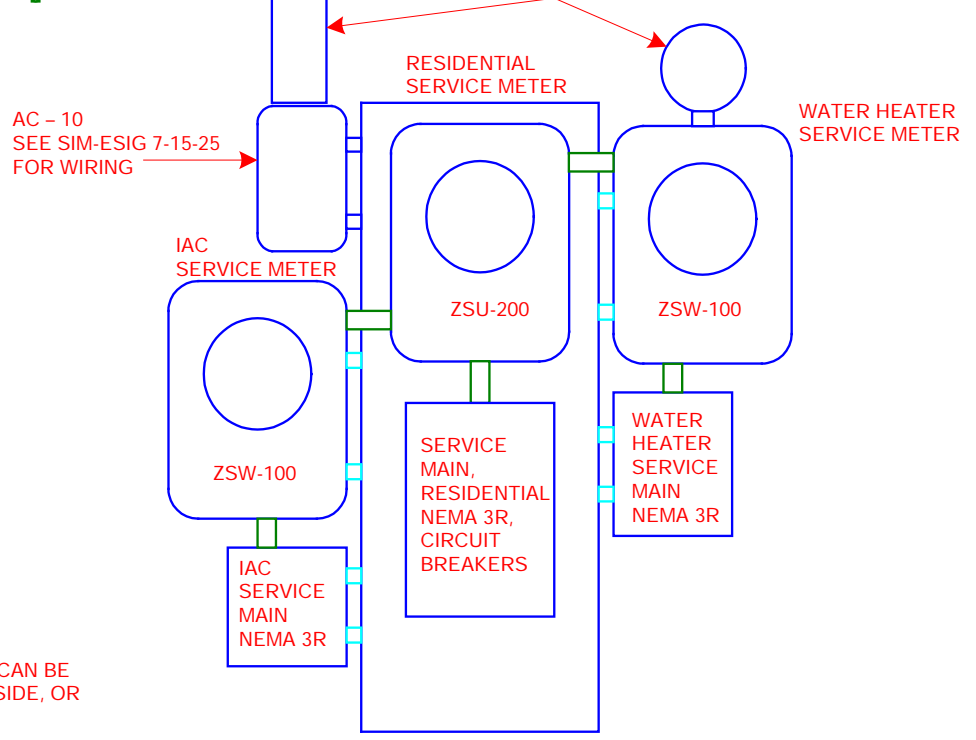
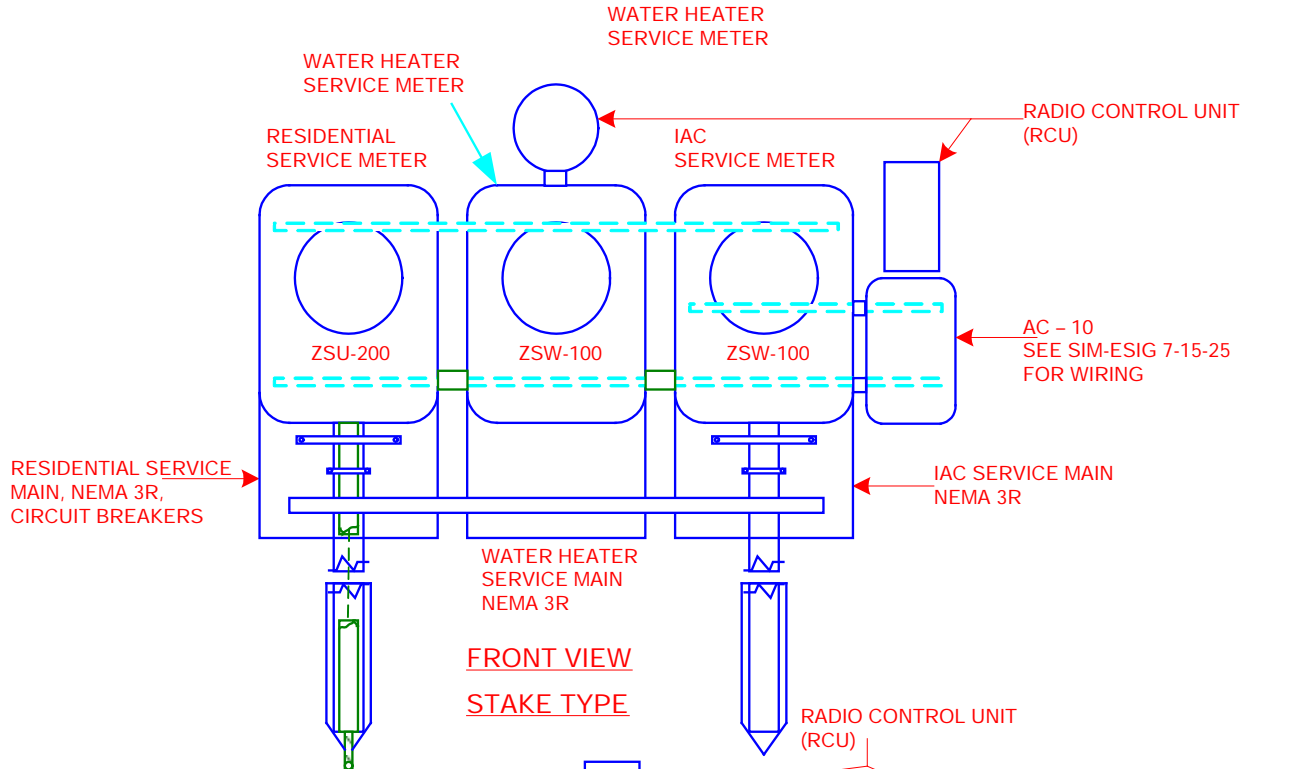

NOTES:

- 1. -- SERVICE EQUIPMENT CAN BE MOUNTED ON FRONT SIDE, OR FLUSH ON BRACKETS.
- 2. -- INSTALLATION DRAWING DETAILED SPECIFICATIONS SEE 3-14-17 THROUGH 3-14-21.

FRONT VIEW TROUGH TYPE

THE DETROIT EDISON COMPANY ASSUMES NO RESPONSIBILITY FOR INJURY OR DAMAGE ARISING FROM THE USE OF THIS SPECIFICATION DIAGRAM.

INTERRUPTIBLE AIR CONDITIONING RATE APPLICATIONS

RESIDENTIAL OR COMMERCIAL

D1, D1.3, D2, OR D3

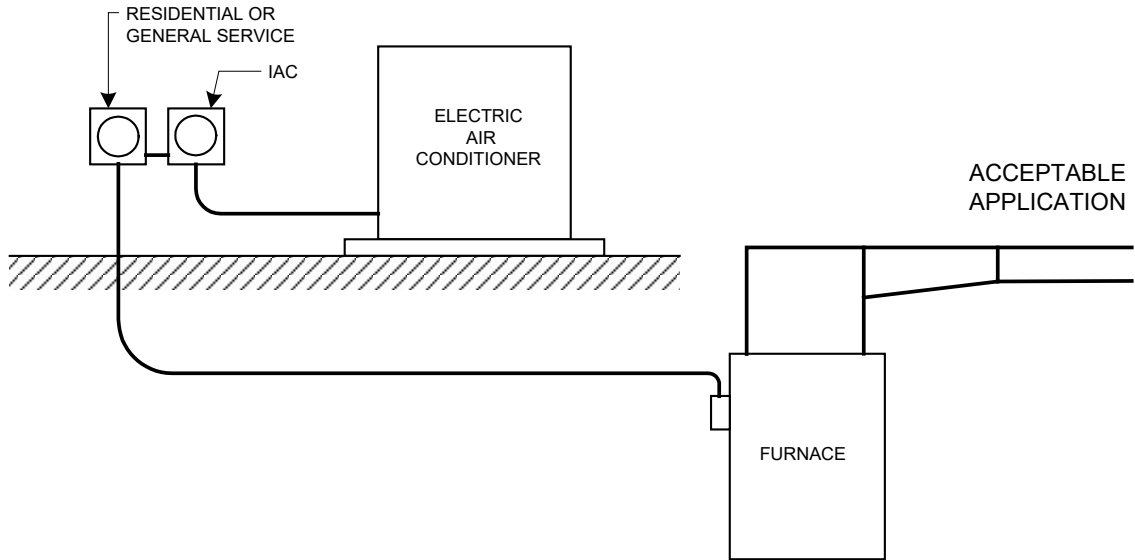

RESIDENTIAL OR COMMERCIAL

D1, D1.3, D2, OR D3

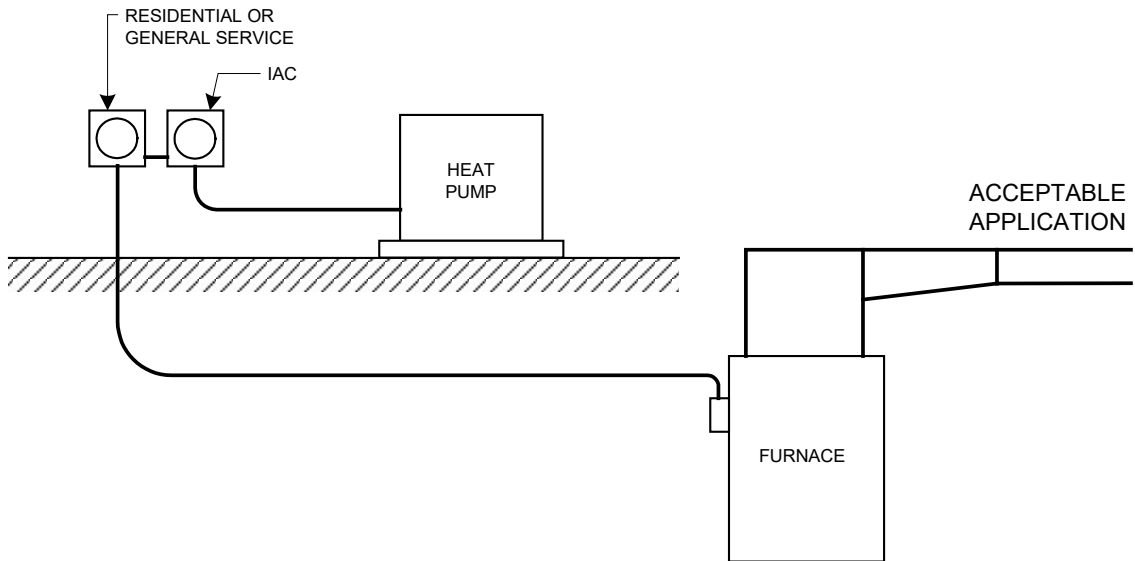

INTERRUPTIBLE AIR CONDITIONING RATE APPLICATIONS

SEPARATE AIR CONDITIONING & HEATING WITH COMMON AIR HANDLER AND DUCT SYSTEM FOR MOBILE HOME, COMMERCIAL, OR RESIDENTIAL DUAL SYSTEM

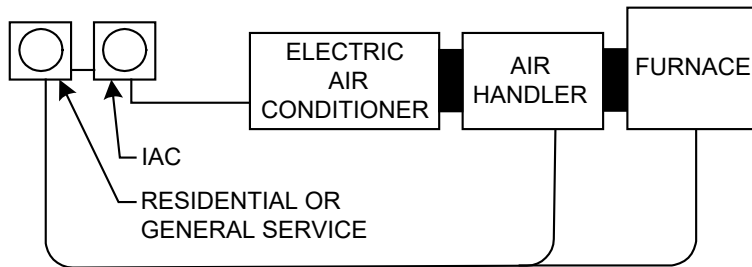

ACCEPTABLE APPLICATION

THROUGH THE WALL OR WINDOW AIR CONDITIONER OR HEAT PUMP

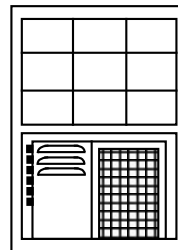
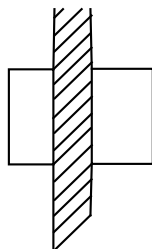

NOT ACCEPTABLE

EXCEPTION: THROUGH THE WALL, DIRECT WIRED, AND DUCTED TO ANOTHER ROOM.

INTERRUPTIBLE AIR CONDITIONING RATE APPLICATIONS

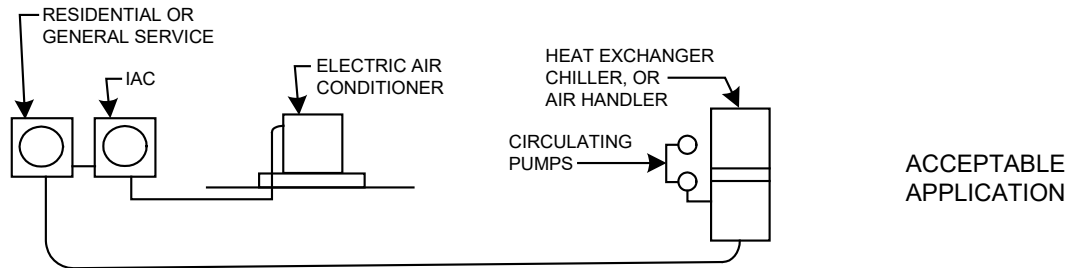
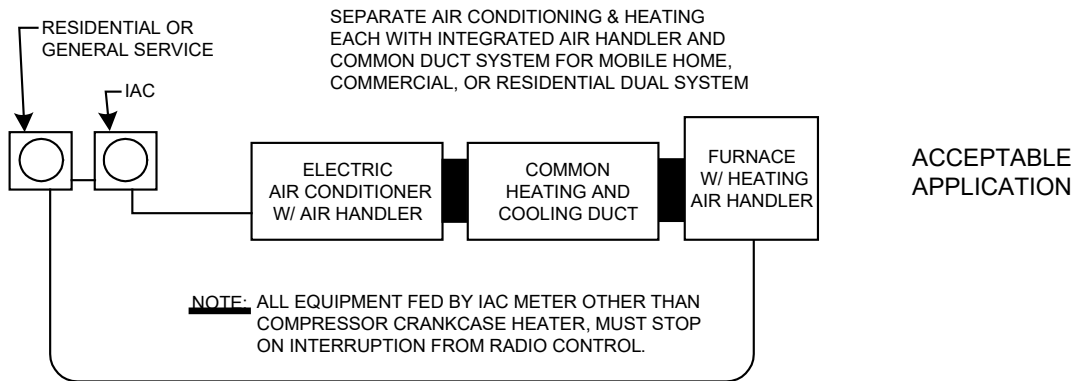
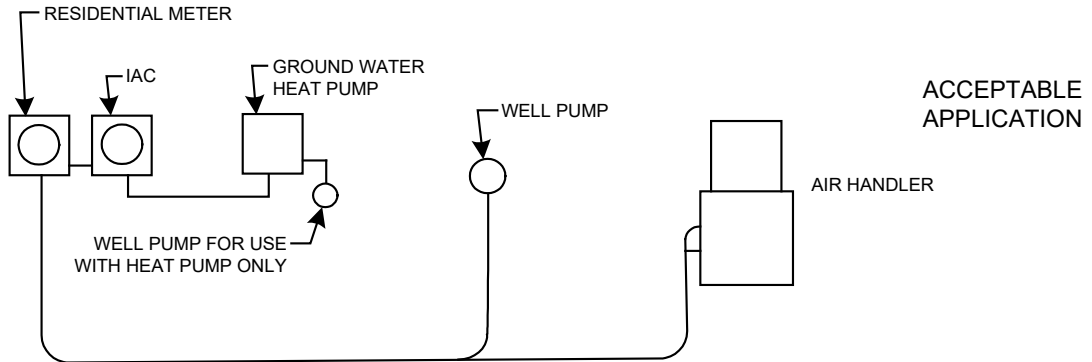

INTRERRUPTIBLE AIR CONDITIONING RATE APPLICATIONS

FARM AND/OR SPACE HEATING

D1.4

TIME OF DAY METER

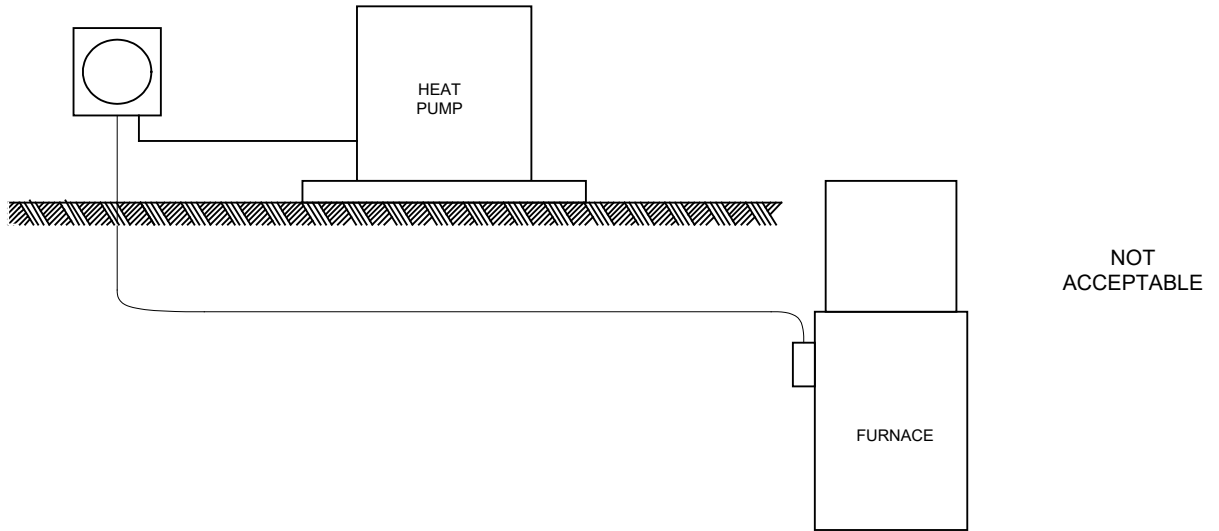

INTERRUPTIBLE RESIDENTIAL SPACE HEATING

DUAL FUEL D2.2

RESIDENTIAL METER

SPACE HEATING METER

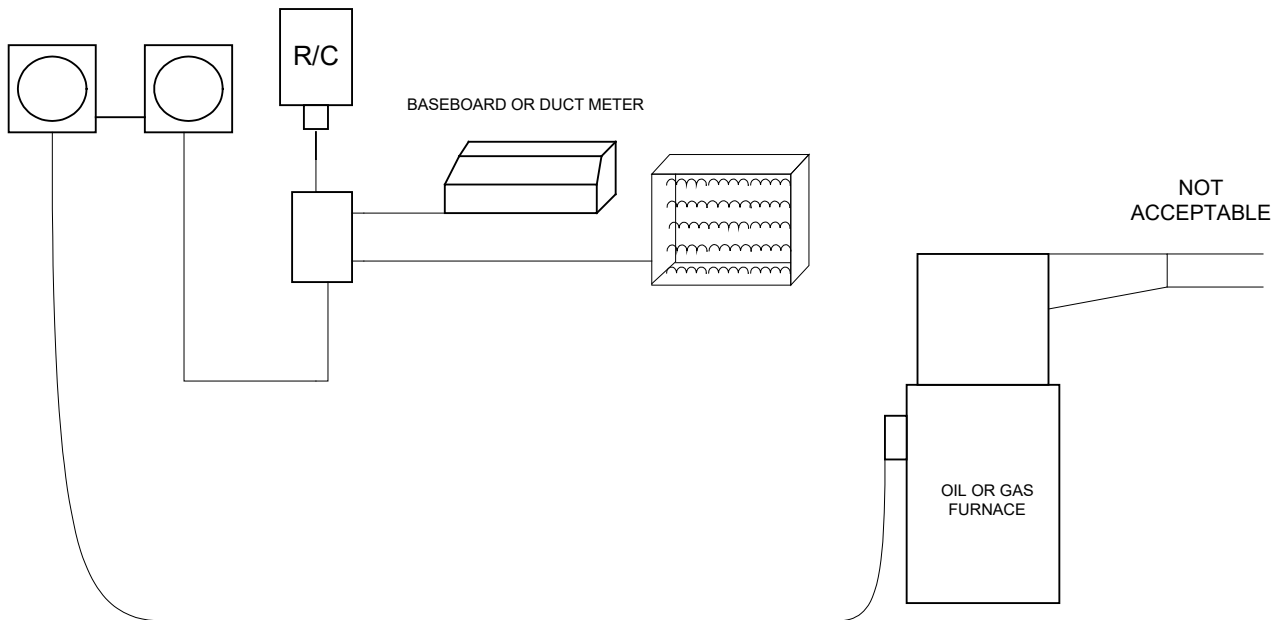

NOTE: R/C OPERATES TO INTERRUPT ONLY HEATING LOAD.
 THE CUSTOMER CAN HAVE ONLY ONE INTERRUPTABLE RATE
 WITH THE EXCEPTION OF ELECTRIC HEATER.

INTERRUPTIBLE SPACE-CONDITIONING RATE D1.1 APPLICATIONS
NOT ELIGIBLE FOR D1.1 RATE

ROOFTOP OR PADMOUNT HVAC
ELECTRIC AIR CONDITIONER WITH GAS HEAT

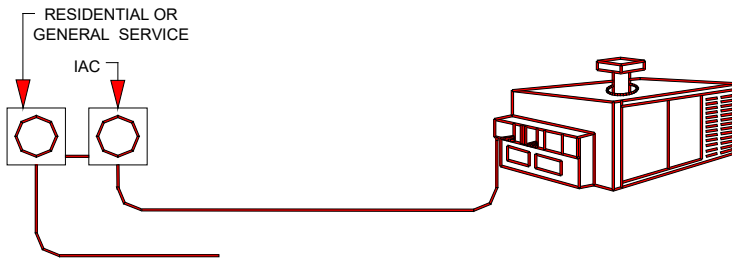

NOT
ACCEPTABLE

THROUGH THE WALL ELECTRIC AIR CONDITIONER
WITH GAS HEAT AND DUCT TO ANOTHER ROOM

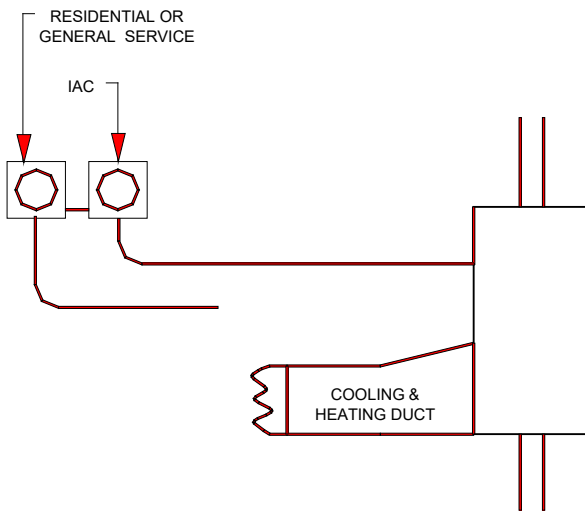

NOT
ACCEPTABLE

LARGE GENERAL SERVICE D4

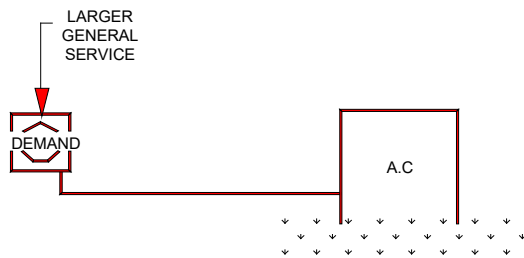

NOT
ACCEPTABLE

**INTERRUPTIBLE GENERAL SERVICE (IGS)
RATE D3.3**

GENERAL

- I. Customers on the General Service Rate D3 may opt to have all or part of their load put on the Interruptible General Service Rate, D3.3. All of the separately metered interruptible load will be interrupted when a Detroit Edison IGS interruption is signaled. At the end of the interruption, motor loads or other loads with large inrush currents may have to be staged to eliminate flicker problems. In addition, Detroit Edison will allow a time delay not to exceed 15 minutes once the IGS interruption is signaled. This time delay could allow a siren, lights or other system to alert personnel of the impending loss of electrical energy. It could also be used to start up an alternate source of electrical energy and allow the facility to transfer to this alternate source. This time delay circuit will ONLY give advanced warning for an IGS interruption. The timing circuit will be subjected to Section V, Control Circuit Security.
- A. Care should be exercised in selecting equipment to be supplied energy from IGS circuits to be certain that safety, maintenance, or inconvenience problems do not arise from interruptions. No advance warning will be given prior to an interruption, nor will there be any scheduling or prediction of interruptions. Transfer circuits are not allowed to maintain operation from firm circuits. See Diagram 7-17-5&6 for Typical Service Configurations.

II. Customer Responsibilities

To be eligible for the IGS Rate, the customer is responsible for making the necessary circuit modifications and for installation of the required control equipment, which includes:

- A. A 24-volt AC source for the Radio Control Unit (RCU) which will require 8 volt-amperes, in addition to any customer load sharing the same transformer.
- B. A relay or switch circuit that will be compatible with the RCU. The RCU will control 24 volts at 3 amps max.
- C. Separate circuitry, switches, meter enclosures, etc. which may be necessary to isolate and control the equipment fed from the IGS meter.
- D. Staging relays - If, at the end of an interruption, the simultaneous start of motors causes a flicker problem, separate time delay relay or relays with a five-second-time delay will be necessary to stagger motor or motor group starts.
- E. Customer will supply the necessary meter enclosures, and the weather resistant box (NEMA 3R) AC-10. The AC-10 enclosure will be approximately 6" high by 4" wide by 2 ¾" deep. It must be UL listed.

III. Detroit Edison Responsibility

Detroit Edison will supply the meter and the RCU. Detroit Edison will install the RCU and the meter when the contractor has completed the wiring requirements.

**INTERRUPTIBLE GENERAL SERVICE (IGS)
RATE D3.3
CONTROL CIRCUIT SCHEMATIC**

IV. Circuit Operation

See Diagram of Control Circuit on 7-17-4.

The Radio Control Unit (RCU) contact directly controls a Pilot Relay. Normally (Uninterrupted Condition) the coil is energized. When the RCU is signaled to interrupt the load, the coil is de-energized. The Pilot Relay has both a Normally Open (N.O.) and a Normally Closed (N.C.) contact.

RESTORATION OPERATION or NORMAL CONDITION

The energized Pilot Relay will close and hold the N.O. contact closed. This will energize the close coil, throwing the main contact mechanism over its spring loaded center to the **close position**. As it passes through the center, the **close coil contacts** (C-1) will open, stopping the control current. At the same time, the **open coil contacts** (O-1) close.

INTERRUPTION OPERATION

The interrupted condition will result when the relay coil is de-energized. This will allow the N.C. contacts to close. This will energize the open coil, throwing the main contact mechanism over its spring loaded center to the **open position**. As it passes through the center, the **open coil contacts** (O-1) will open, stopping the control current. At the same time, the **close coil contacts** (C-1) close.

ANTI-PUMP

Only one momentary coil operating contact (O-1 or C-1) can be closed at the same time. Upon failure of the pilot relay contacts a pumping action can occur with the breaker or switch if both O-1 and C-1 contacts are closed at the same time. O-1 and C-1 contacts also protect the main contact coils from being damaged by not allowing a sustained current through them.

MAIN CONTACT MECHANISM

The spring loading on the main contact mechanism holds the main contacts open or closed.

The schematic diagram (7-17-4) follows the convention of showing relay contacts in the de-energized position.

The chart below shows contact position and current paths in close and open operations.

RESTORATION OPERATION (NORMAL CONDITION)

RCU	PILOT RELAY		MECHANICALLY HELD SWITCH		
	Contact Closed	Coil Energized	Current Path NO Contact Closed	Spring Over Center Contact Position	
Start				End	Mechanism swings and latches the contacts closed
C-1 Closed O-1 Open				C-1 Open O-1 Closed	

INTERRUPTION OPERATION (LOAD INTERRUPTION)

RCU	PILOT RELAY		MECHANICALLY HELD SWITCH		
	Contact Open	Coil Not Energized	Current Path NC Contact Closed	Spring Over Center Contact Position	
Start				End	Mechanism swings and latches the contacts open
C-1 Open O-1 Closed				C-1 Closed O-1 Open	

INTERRUPTIBLE GENERAL SERVICE (IGS)

**RATE D3.3
CONTROL CIRCUIT SCHEMATIC****V. Control Circuit Security**

All enclosures associated with the IGS control circuit shall be sealed. This includes enclosures for the IGS RCU, AC-10, Pilot Relay, 24 Volt Transformer, Control Circuit Overcurrent Protective Device (OCPD), Time Delay Circuit if used and Interruptible Circuit Switch. This will ensure the security of the IGS control circuit and rate.

An emergency situation may necessitate the breaking of Detroit Edison seals. Immediately following such action, Detroit Edison must be notified so that they can again be resealed.

A lamp or similar device should be used to indicate that the transformer OCPD and circuit integrity are still good. Immediately upon loss of 24 volts the control circuit operating potential should be restored. This will necessitate the breaking of the Detroit Edison seal and subsequent repairs. Immediately notify Detroit Edison of these actions.

In the event that non-emergency maintenance or inspection is necessary, Detroit Edison must be contacted for permission to break the seal.

Figure 7-17-6 (“Control Circuit Layout”). These enclosures will have an IGS sticker applied to check them. The sticker reads:

“Detroit Edison
INTERRUPTIBLE
GENERAL SERVICE
If Seal Is Broken Call:
1-800-477-4747”

VI. Circuit Modifications

Variations of this control circuit or other proposed circuitry for complying with the control requirements of this rate must be presented in detail to the Service Planner who will consult with Meter Engineering. This must be done prior to any construction.

INTERRUPTIBLE GENERAL SERVICE (IGS) RATE D3.3 CONTROL CIRCUIT SCHEMATIC

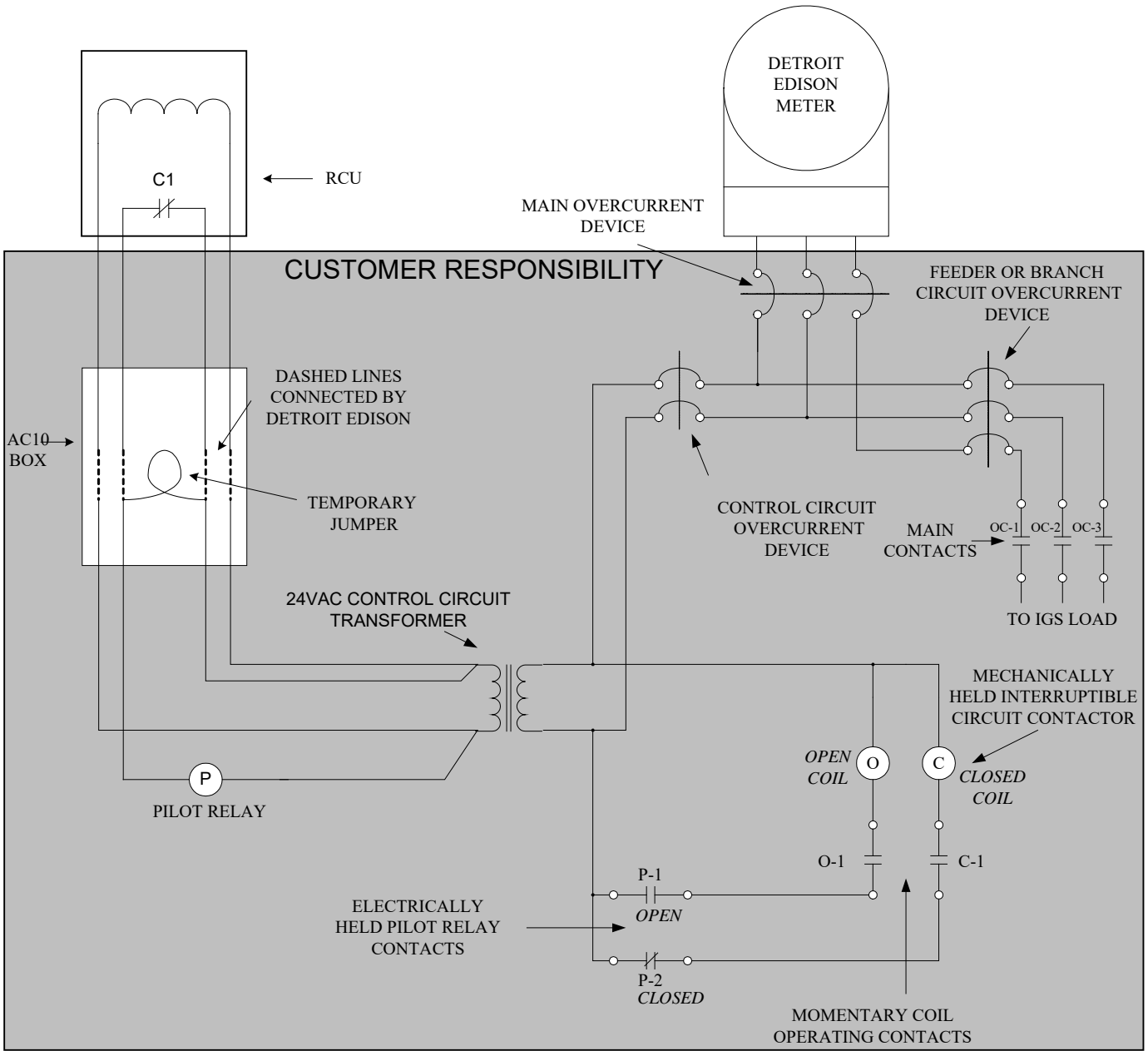

**NOTE* CIRCUIT DRAWN ILLUSTRATES
NORMAL UNINTERRUPTED SERVICE**

THE DETROIT EDISON COMPANY ASSUMES NO RESPONSIBILITY FOR INJURY
OR DAMAGE ARISING FROM THE USE OF THIS SPECIFICATION DIAGRAM.

**INTERRUPTIBLE GENERAL SERVICE (IGS)
RATE D3.3
CONTROL CIRCUIT EQUIPMENT ASSEMBLY**

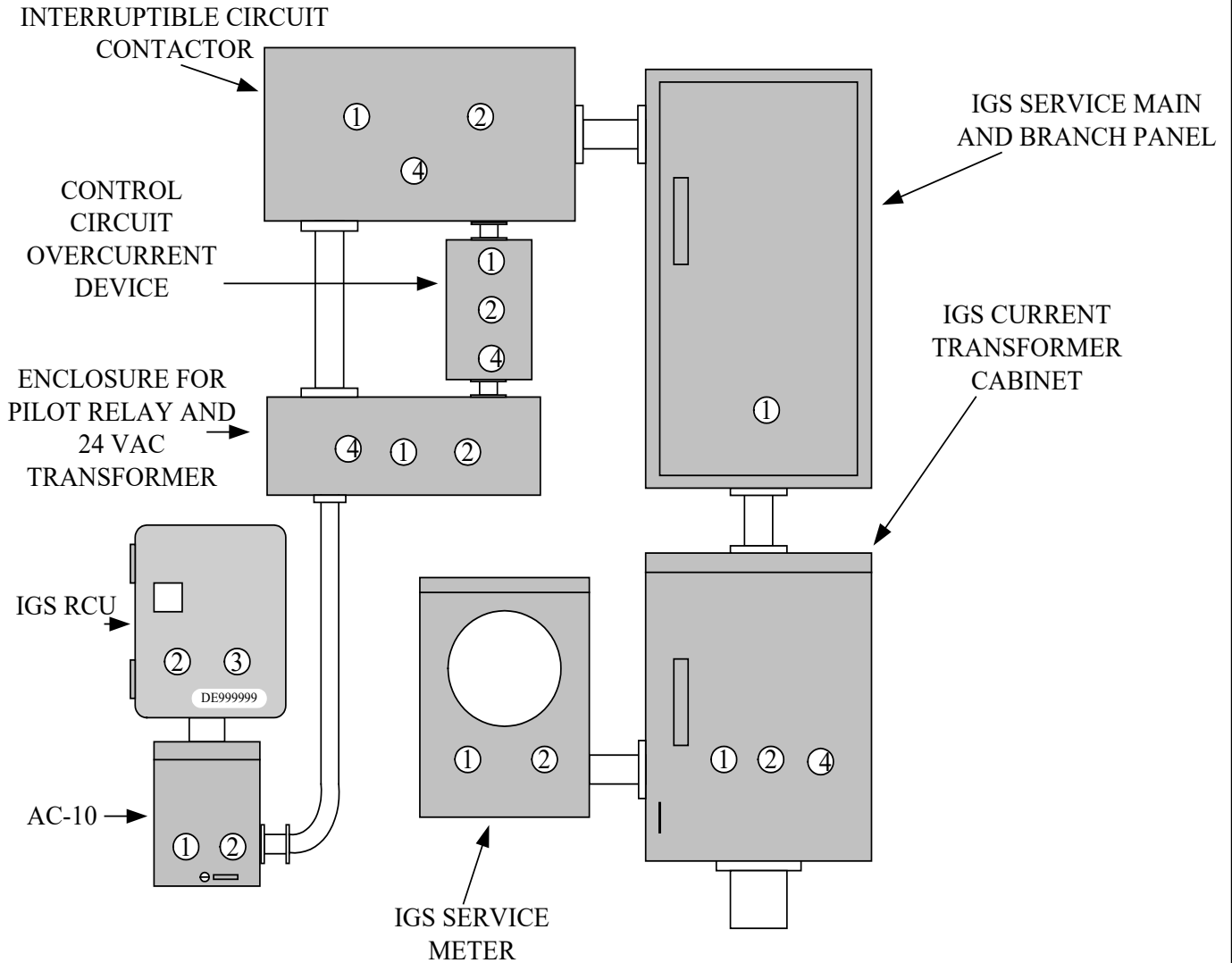

- 1. FURNISHED AND INSTALLED BY CONTRACTOR
- 2. SEALABLE ENCLOSURE
- 3. FURNISHED AND INSTALLED BY DETROIT EDISON
- 4. IGS STICKER

THE DETROIT EDISON COMPANY ASSUMES NO RESPONSIBILITY FOR INJURY OR DAMAGE ARISING FROM THE USE OF THIS SPECIFICATION DIAGRAM

**INTERRUPTIBLE GENERAL SERVICE
(IGS)
RATE D3.3**

CONTROL CIRCUIT LAYOUT

RCU = RADIO CONTROL UNIT
OCPD = OVER CURRENT
PROTECTIVE DEVICE

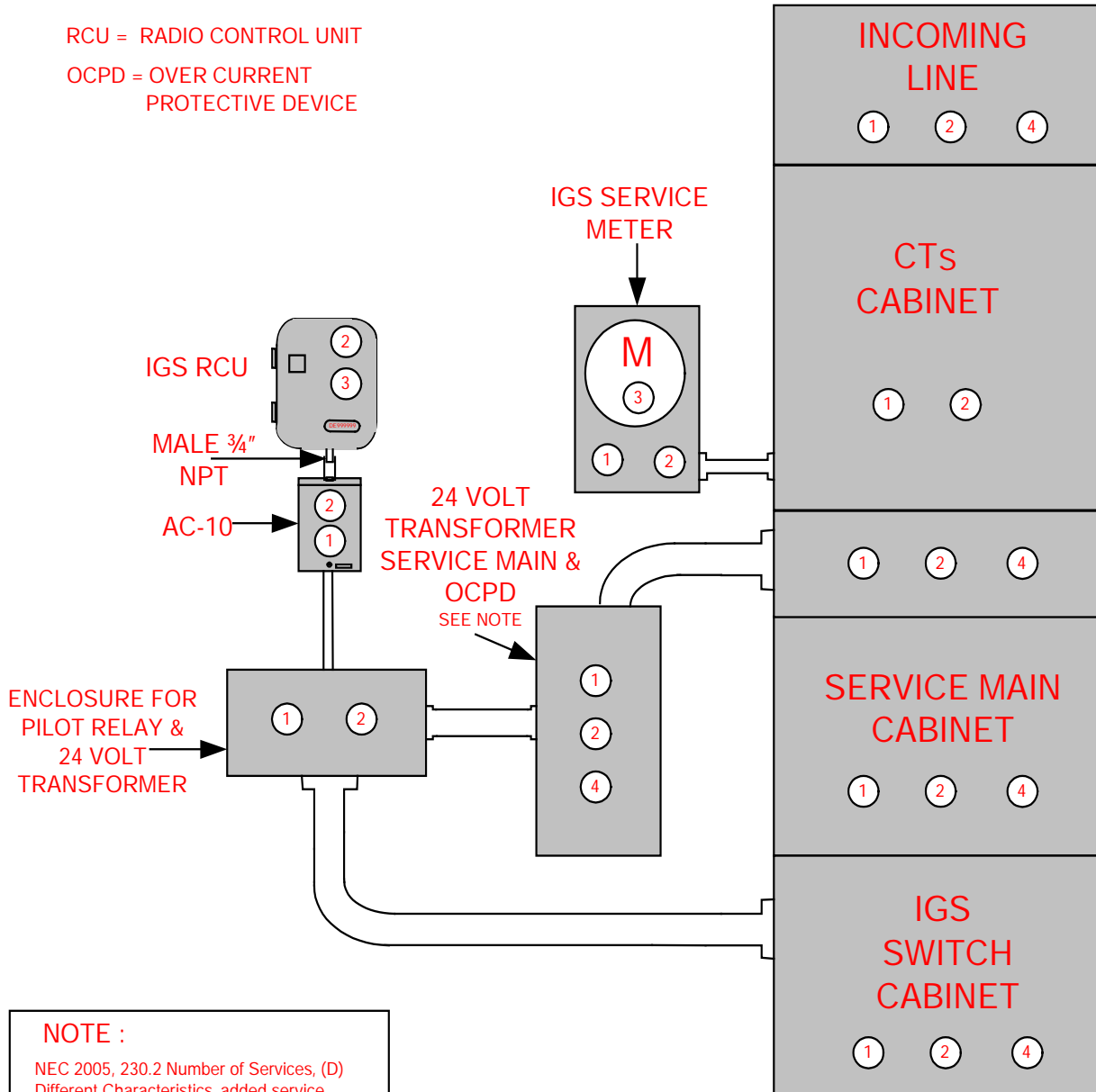

NOTE :

NEC 2005, 230.2 Number of Services, (D) Different Characteristics, added service permitted for different rate schedules.
NEC 2005, 230.72 Grouping of disconnects.
NEC 2005, 230.82 Equipment Connected to the Supply Side of Service Disconnect, (5) "Taps used only to supply load management devices".

- ① FURNISHED AND INSTALLED BY CONTRACTOR
- ② SEALABLE ENCLOSURE
- ③ FURNISHED AND INSTALLED BY DETROIT EDISON
- ④ IGS STICKER APPLIED

THE DETROIT EDISON COMPANY ASSUMES NO RESPONSIBILITY FOR INJURY OR DAMAGE ARISING FROM THE USE OF THIS SPECIFICATION DIAGRAM.

RESIDENTIAL SUPPLEMENTAL SPACE HEATING RATE D1.5

This rate is available to customers with permanently installed supplemental electric space heating totaling 3 KW or more. It will be supplied by a separate meter and billed at Rate D1.5. Contact Detroit Edison Planning and Design for confirmation before starting the installation.

1. The meter connection diagram (7-18-2) for the Residential Supplemental Space Heating Service Rate shows typical methods for separate meter installations.
2. The Residential Supplemental Space Heating Rate Meter enclosure will be furnished by the Contractor. A 200A Enclosure will accommodate most installations, however the Service Planner may choose to issue a larger capacity enclosure if conditions warrant.
3. The interconnections between the Residential Service meter and the Supplemental Space Heating meter will be sized to serve the current requirements of the customer's heating system.

If the interconnection will be tapped onto a water heater rate meter, the interconnection to the water heater meter must be sized for the total load of both appliances. Wherever conductors meet in a terminal, they must be of the same metal; that is, copper-to-copper or aluminum-to-aluminum. In all cases, the minimum size allowed is #10 AWG copper. Flexible metal conduit (FMC) is not allowed between the meter enclosures.

4. The contractor will connect the Supplemental electric Heat Service to the load side of the Residential service meter leaving enough slack to easily reach the line terminals. Detroit Edison personnel will move the conductors to the line side when the installation is put in service.

Exceptions:

- (a) Supply of the electric heat meter from a separate service riser or from connection to service conductors in a sealable trough.
 - (b) Interconnect conductor size is number 6 AWG and larger.
 - (c) New service that has not been energized.
 - (d) If the Electric Heat meter must be interconnected from the Water Heater Meter, the connection will be to the load side of the Water Heater Meter.
DO NOT CONNECT TO WATER HEATER RADIO CONTROL CIRCUIT.
 - (e) The supplemental Heat main switch and distribution panel must be separate from the customer's main branch panel.
5. Conductor metal must be compatible with the line side conductors – even though the temporary connection will be to the load side. (AL to AL or CU to CU) When connection is made to the line and jumpers are installed, DECo must be notified immediately and informed that the installation is line fed by exception.

RESIDENTIAL SUPPLEMENTAL HEATING RATE D1.1 METER FEED

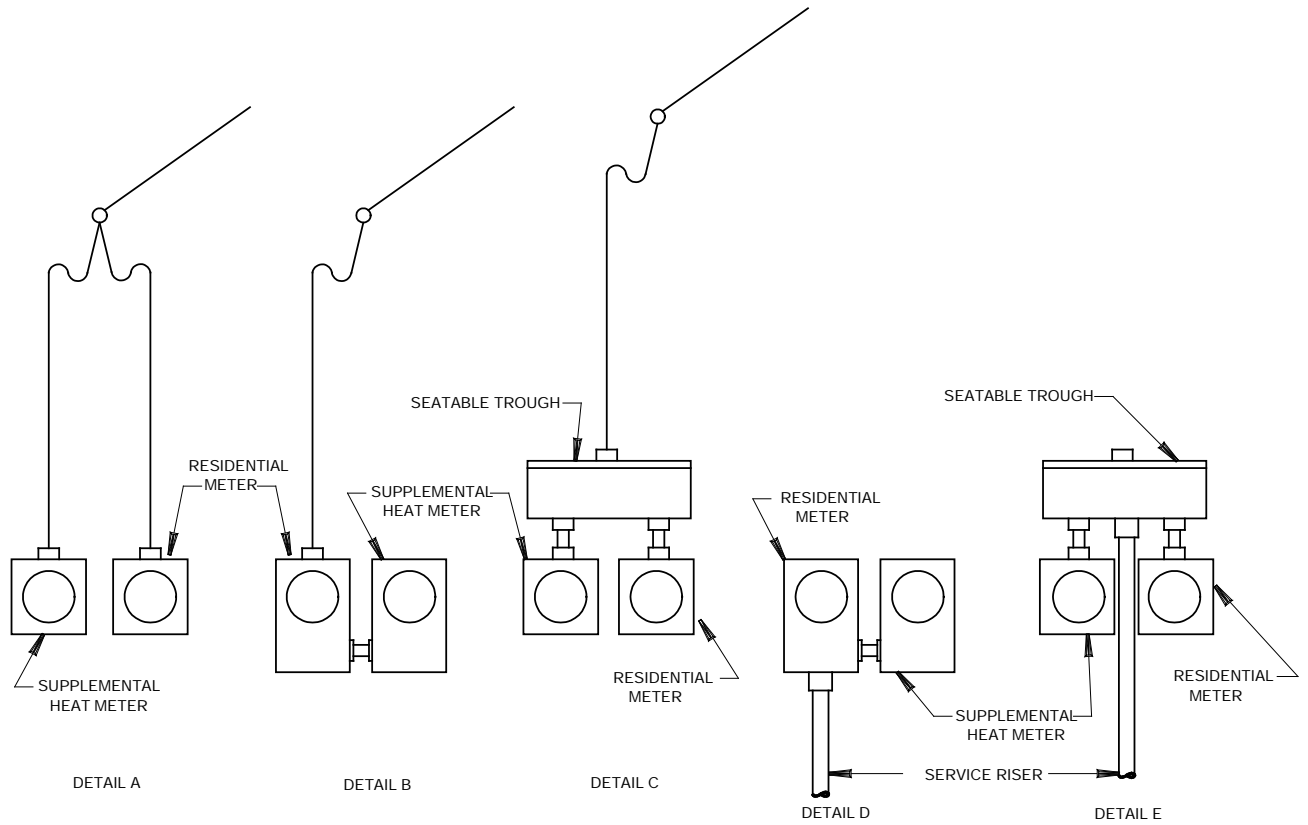

ALTERNATE METHODS OF CONNECTING THE RESIDENTIAL SUPPLEMENTAL SPACE HEATING METER

NOTES :

1. METHODS SHOWN IN DETAIL A, C, AND E WILL USE THE APPROPRIATE SUPPLEMENTAL SPACE HEATING RATE METER BOX WITH HUB ACCORDING TO HEATING LOAD DEMAND. CONSULT SERVICE PLANNER.
2. METHOD SHOWN IN DETAILS B AND D LIMITED TO MAXIMUM #4 AWG WIRE SIZE OR TERMINATION LIMITATIONS OF METER BLOCK. . USE WITH CLASS 200A METER ENCLOSURE ONLY.
3. IF DEMAND EXCEEDS SELF-CONTAINED METER CURRENT RATING, CONSULT WITH PLANNING AND DESIGN.

ELECTRIC WATER HEATER WIRING CONNECTIONS
FOR DETROIT EDISON WATER HEATER RATES
SINGLE PHASE - SINGLE STANDARD WATER HEATER

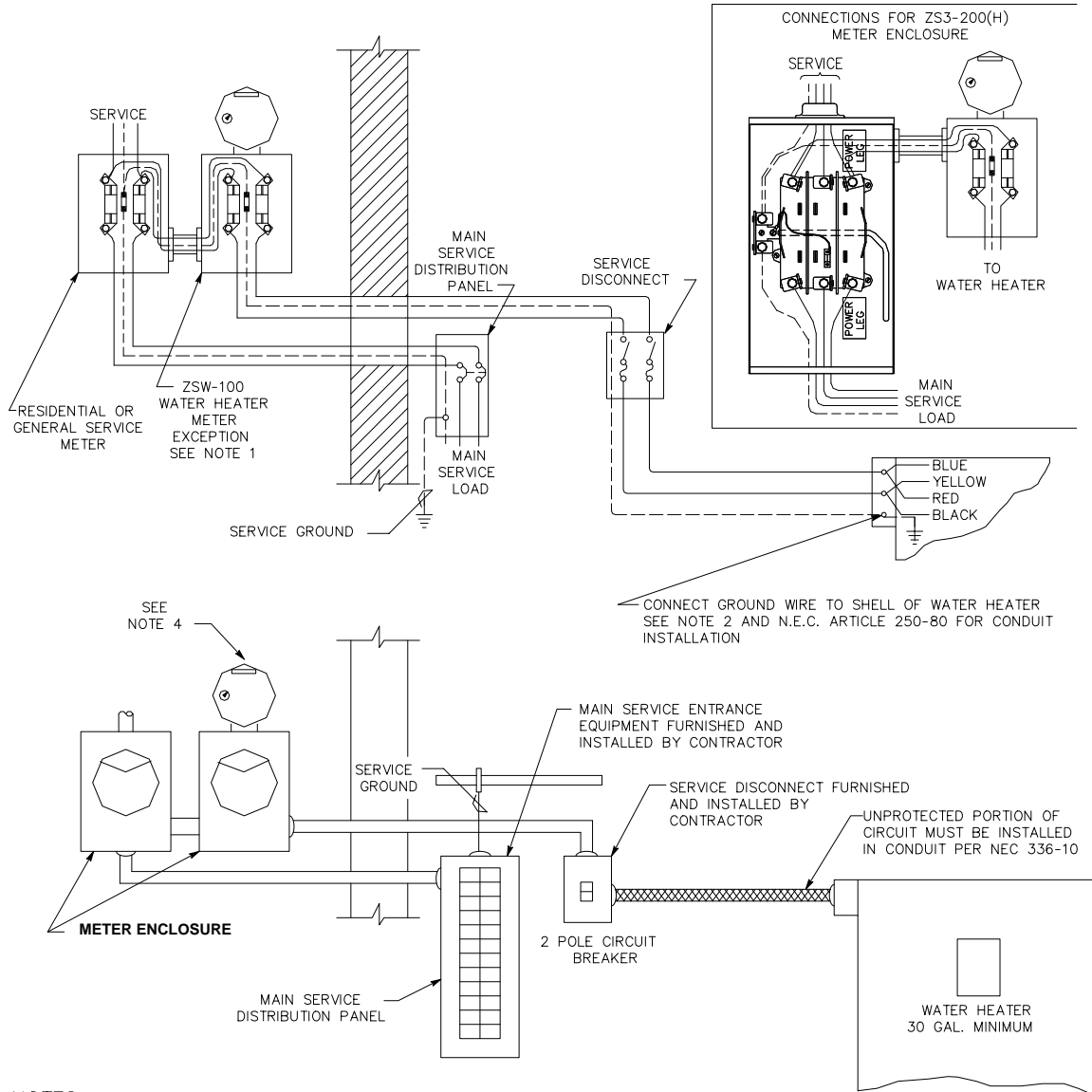

NOTES:

1. 120/208V, WYE SERVICE WILL REQUIRE ZS-100-Y INSTEAD OF ZSW-100 AND A NEUTRAL CONDUCTOR FROM THE SERVICE METER ENCLOSURE NEUTRAL TO THE ZS-100-Y NEUTRAL.
2. WHEN PLASTIC WATER PIPE IS USED, CONNECT THE GROUND WIRE TO THE SHELL OF WATER HEATER, THEN CONNECT GROUND WIRE TO THE METALLIC COLD WATER INLET PIPE OF THE WATER HEATER WITH AN APPROVED GROUND CLAMP.
3. THESE CONDUCTORS MUST BE INSTALLED TO COMPLY WITH N.E.C. SERVICE ENTRANCE REQUIREMENTS. THIS COULD BE FOUR WIRE WITH GROUND WATER HEATER CABLE (TWO UNUSED CONDUCTORS), THREE WIRES IN CONDUIT OR A CABLE LISTED OR MARKED FOR SERVICE ENTRANCE USE. NO UF CABLE OR ROMEX BETWEEN THE METER AND SERVICE DISCONNECT.
4. RADIO CONTROL UNIT FURNISHED AND INSTALLED BY DETROIT EDISON.

THE DETROIT EDISON COMPANY ASSUMES NO RESPONSIBILITY FOR INJURY OR DAMAGE ARISING FROM THE USE OF THIS SPECIFICATION DIAGRAM.

ELECTRIC WATER HEATER WIRING CONNECTIONS
FROM A CURRENT TRANSFORMER CABINET
VOLTS - 120/240 OR 120/208 (SEE NOTE 4)

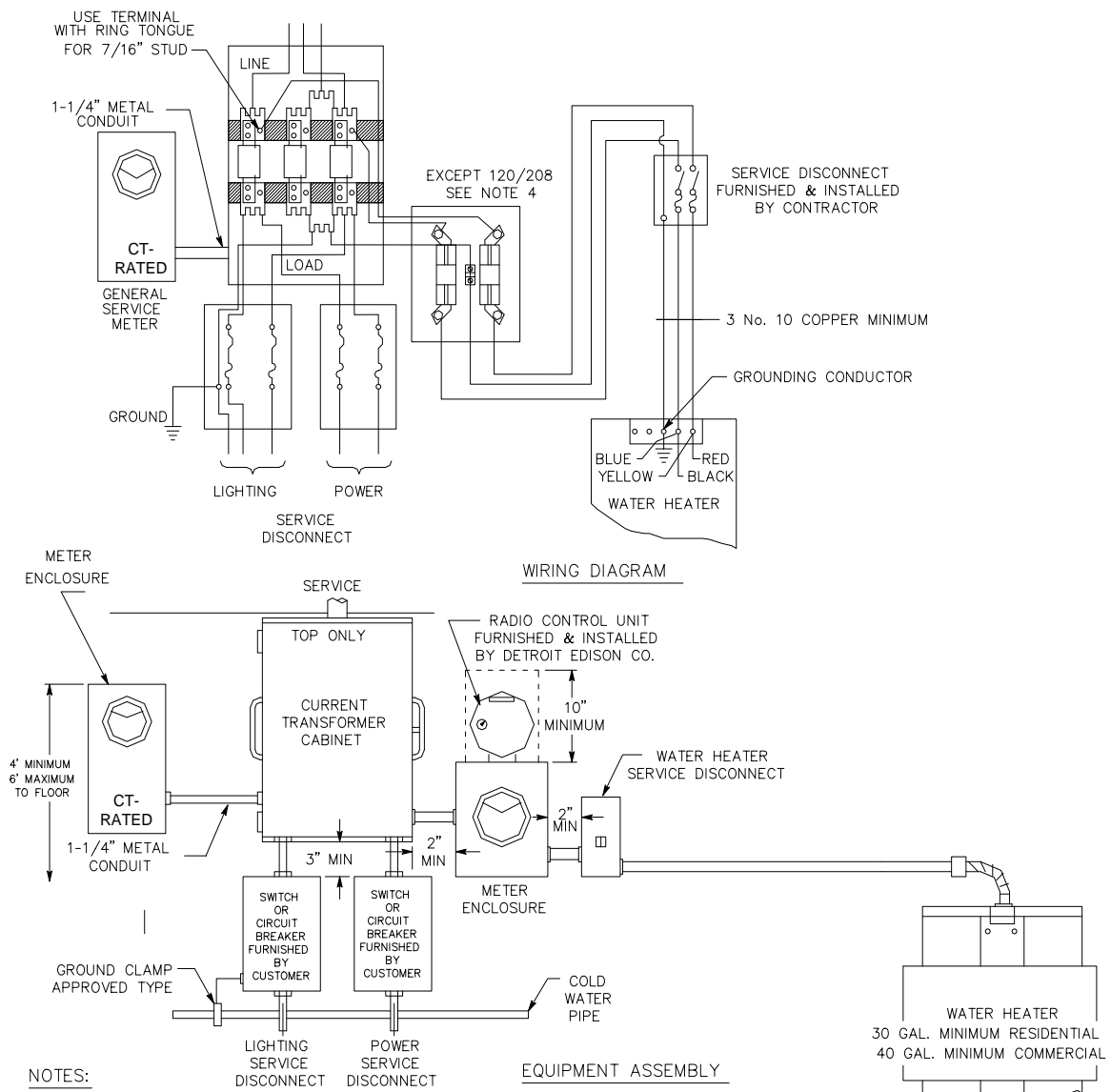

THE DETROIT EDISON COMPANY ASSUMES NO RESPONSIBILITY FOR INJURY OR DAMAGE ARISING FROM THE USE OF THIS SPECIFICATION DIAGRAM.

480 VOLT SINGLE PHASE WATER HEATER
 277/480 VOLT SERVICE
 SINGLE STANDARD WATER HEATER
 6 KW MAXIMUM DEMAND

MULTIPLE HEATER, MULTIPLE ELEMENT HEATER OR HIGH WATTAGE HEATER SEE OTHER PAGES THIS SECTION

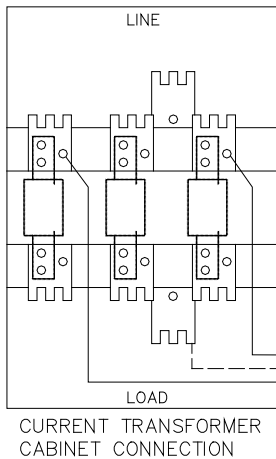
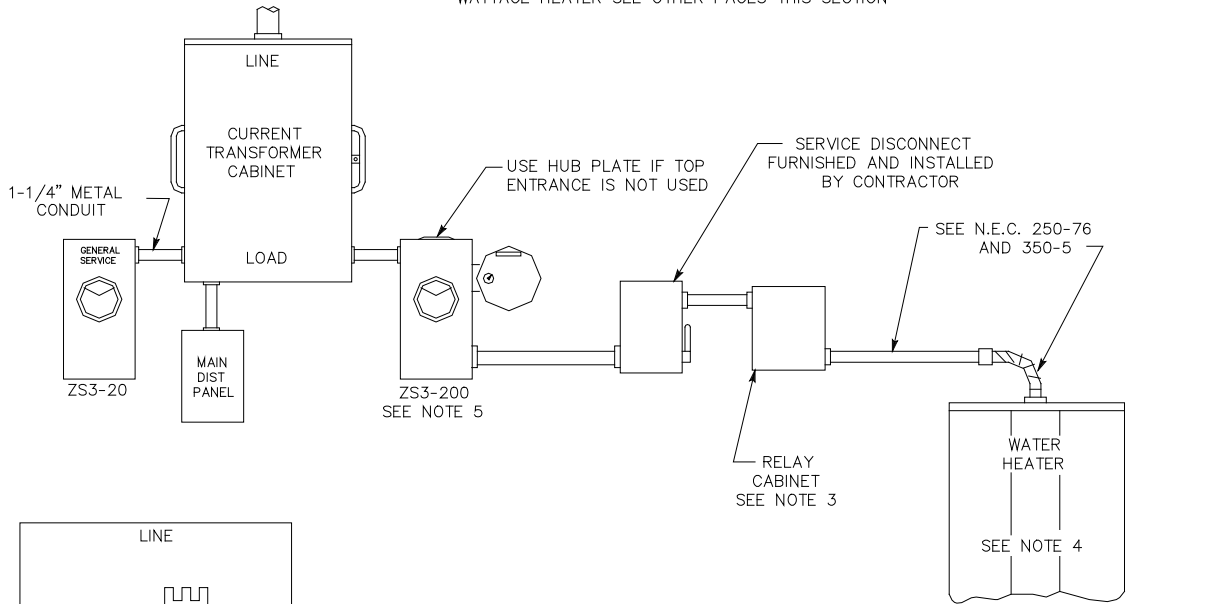

SELF-CONTAINED METER CONNECTION

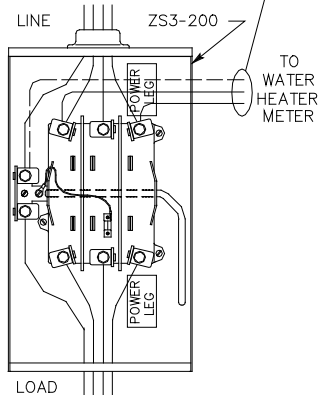

METER MANUAL 6-5-9

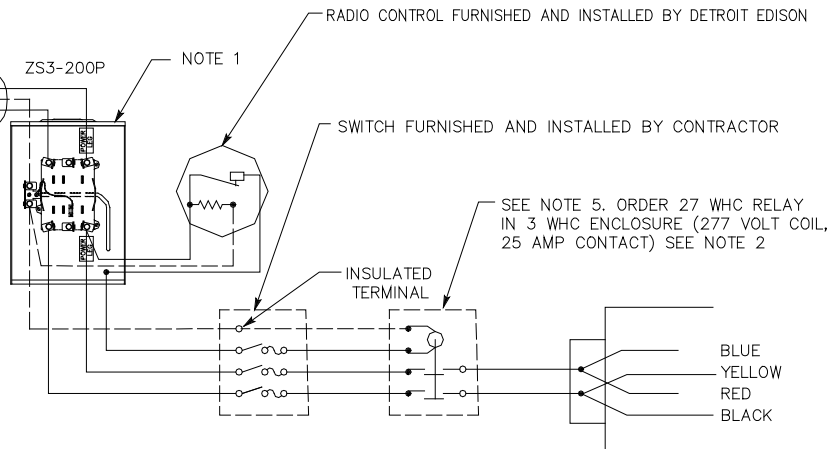

NOTES:

- 1 - METER MUST BE SPECIAL ORDERED. CLASS 200, 480V, 10. CONSULT INDUSTRIAL/COMMERCIAL REP WHO WILL SPECIAL ORDER FROM CUSTOMER FIELD CENTER METER SHOP.
- 2 - WATER HEATER METER AND RELAY MUST BE GROUPED WITH GENERAL SERVICE METER.
- 3 - FURNISHED AND INSTALLED BY CONTRACTOR.
- 4 - WATER HEATER MUST BE 480 VOLT. NO LINE TO NEUTRAL (277 VOLT) ELEMENTS ALLOWED.
- 5 - ALL WIRING SHOULD BE INSTALLED BY AN ELECTRICAL CONTRACTOR.

THE DETROIT EDISON COMPANY ASSUMES NO RESPONSIBILITY FOR INJURY OR DAMAGE ARISING FROM THE USE OF THIS SPECIFICATION DIAGRAM.

ELECTRIC WATER HEATER WIRING CONNECTIONS FOR
DETROIT EDISON CONTROLLED WATER HEATER RATES
120/240 OR 120/208 VOLT CONTACTOR CONTROLLED
(SEE NOTE 1)

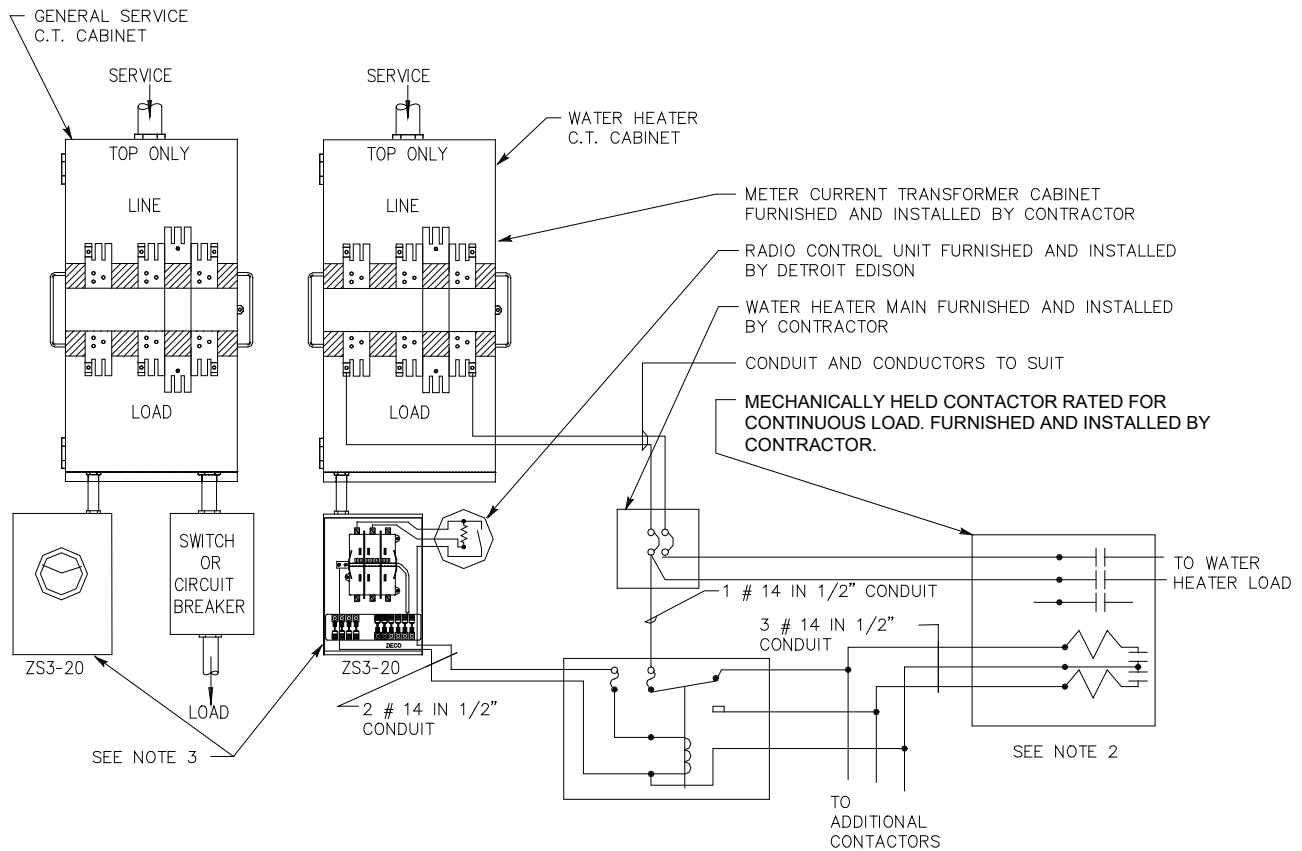

NOTES:

- 1 - USE THIS CIRCUIT ONLY IF LOAD EXCEEDS 100 AMPS OR FOR SPECIAL WATER HEATERS WITH THREE PHASE ELEMENTS. REQUIRES SERVICE PLANNER APPROVAL. SERVICE PLANNER WILL CONSULT WITH METER AND TECHNICAL SERVICES, AND FIELD SERVICES.
- 2 - MECHANICALLY HELD CONTACTOR RATED FOR CONTINUOUS LOAD FURNISHED AND INSTALLED BY CONTRACTOR.
- 3 - GENERAL SERVICE AND WATER HEATER SERVICE METER ENCLOSURES FURNISHED AND INSTALLED BY CONTRACTOR. INSTALL 1-1/4" METAL CONDUIT BETWEEN CT CABINET AND ZS3-20.

TYPICAL LOAD ARRANGEMENTS:

- 1 - DIRECT FEED TO WATER HEATER(S).
- 2 - FEED TO DISTRIBUTION PANEL WHICH PROVIDES LOWER AMPERAGE PROTECTION TO INDIVIDUAL WATER HEATERS OR TO INDIVIDUAL SETS OF ELEMENTS IN MULTIPLE ELEMENT WATER HEATERS.
- 3 - SAME AS TWO, EXCEPT THAT WATER HEATERS MAY BE LOCATED THROUGHOUT BUILDING AT OR CLOSE TO POINT OF USE. (REQUIRES SPECIFIC APPROVAL OF CUSTOMER SERVICE ENGINEERING AND CUSTOMER FIELD SERVICES). ALSO REQUIRES SWITCH ON SAME FLOOR AS WATER HEATER (N.E.C. 422-24).

THE DETROIT EDISON COMPANY ASSUMES NO RESPONSIBILITY FOR INJURY OR DAMAGE ARISING FROM THE USE OF THIS SPECIFICATION DIAGRAM.

ELECTRIC WATER HEATER WIRING CONNECTIONS FOR
DETROIT EDISON CONTROLLED WATER HEATER RATES
120/240 OR 120/208 VOLT CONTACTOR CONTROLLED
(SEE NOTE 1)

OTHER POSSIBLE EQUIPMENT COMBINATIONS

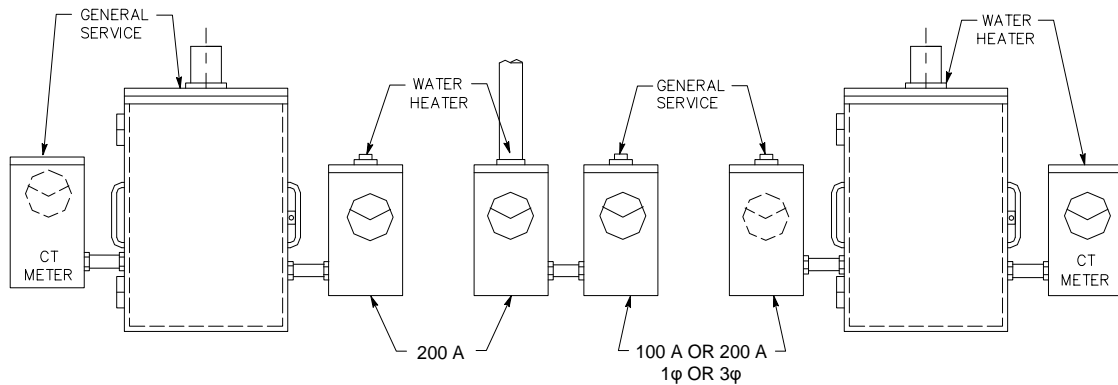

NOTES:

- 1 - USE THIS CIRCUIT ONLY IF LOAD EXCEEDS 100 AMPS OR FOR SPECIAL WATER HEATERS WITH THREE PHASE ELEMENTS. REQUIRES SERVICE PLANNER APPROVAL. SERVICE PLANNER WILL CONSULT WITH CUSTOMER SERVICE ENGINEERING AND CUSTOMER FIELD SERVICES.
- 2 - MECHANICALLY HELD CONTACTOR FOR CONTINUOUS LOAD. FURNISHED AND INSTALLED BY CONTRACTOR
- 3 - GENERAL SERVICE AND WATER SERVICE METER ENCLOSURE FURNISHED AND INSTALLED BY CONTRACTOR. INSTALL 1- $\frac{1}{2}$ " METAL CONDUIT BETWEEN CT CABINET AND ZS3-20.

TYPICAL LOAD ARRANGEMENTS:

- 1 - DIRECT FEED TO WATER HEATER(S).
- 2 - FEED TO DISTRIBUTION PANEL WHICH PROVIDES LOWER AMPERAGE PROTECTION TO INDIVIDUAL WATER HEATERS OR TO INDIVIDUAL SETS OF ELEMENTS IN MULTIPLE ELEMENT WATER HEATERS.
- 3 - SAME AS TWO, EXCEPT THAT WATER HEATERS MAY BE LOCATED THROUGHOUT BUILDING AT OR CLOSE TO POINT OF USE. (REQUIRES SPECIFIC APPROVAL OF CUSTOMER SERVICE ENGINEERING AND CUSTOMER FIELD SERVICES). ALSO REQUIRES SWITCH ON SAME FLOOR AS WATER HEATER (N.E.C. 422-24).

THE DETROIT EDISON COMPANY ASSUMES NO RESPONSIBILITY FOR INJURY OR DAMAGE ARISING FROM THE USE OF THIS SPECIFICATION DIAGRAM.

WIRING CONNECTIONS FOR SEPARATELY METERED APPROVED ELECTRIC WATER HEATER RELAY CONTROLLED OFF-PEAK SERVICE

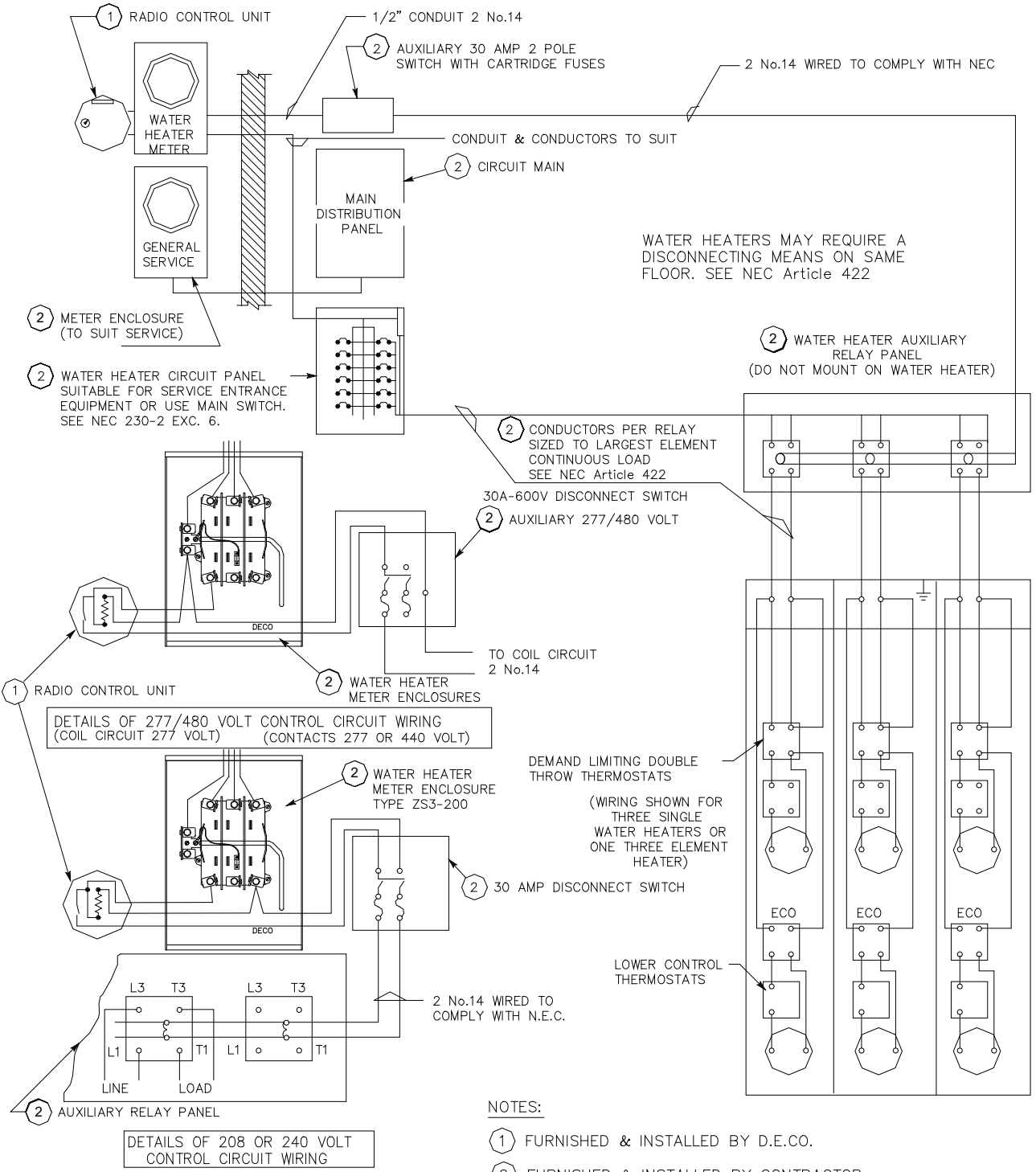

THE DETROIT EDISON COMPANY ASSUMES NO RESPONSIBILITY FOR INJURY OR DAMAGE ARISING FROM THE USE OF THIS SPECIFICATION DIAGRAM.

WIRING CONNECTIONS FOR APPROVED ELECTRIC WATER HEATERS ONE CUSTOMER WITH MULTIPLE WATER HEATERS

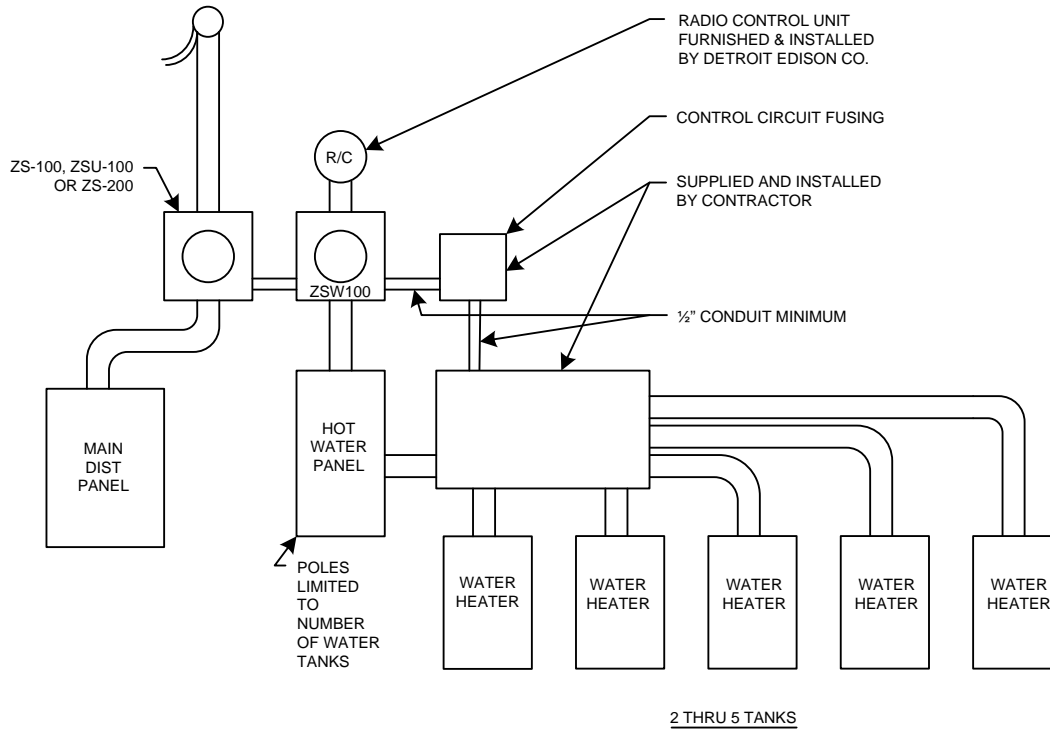

NOTES:

- 1 - SERVICE CONDUCTORS MUST BE INSTALLED TO COMPLY WITH N.E.C. SERVICE ENTRANCE REQUIREMENTS. THIS CAN BE SERVICE ENTRANCE CABLE OR CABLE IN CONDUIT. TYPE UF, NMC OR NM NON METALLIC SHEATHED CABLE IS NOT ACCEPTABLE.
- 2 - ALL WIRING SHOULD BE INSTALLED BY AN ELECTRICAL CONTRACTOR.
- 3 - WHEN PLASTIC WATER PIPE IS USED CONNECT GROUND WIRE TO SHELL OF WATER HEATER THEN CONNECT GROUND WIRE TO THE METALLIC COLD WATER INLET PIPE OF THE WATER HEATER. REFER TO 2005 N.E.C. 250.52(A)(1) "METAL UNDERGROUND WATER PIPE", 2005 N.E.C. 250.32 "BUILDINGS OR STRUCTURES SUPPLIED BY FEEDER(S) OR BRANCH CIRCUIT(S)", 2005 N.E.C. 547.9(B) "SERVICE DISCONNECTING MEANS AND OVERCURRENT PROTECTION AT THE BUILDINGS(S) OR STRUCTURE(S)", (3) "GROUNDING AND BONDING."
- 4 - ALL WIRING MUST COMPLY WITH THE 2005 N.E.C. 422.10, 422.11(1),(3) & 422.13.
- 5 - CONTRACTOR IS RESPONSIBLE FOR AND WILL SUPPLY ALL REQUIRED RELAYS.
- 6 - THE DETROIT EDISON COMPANY ASSUMES NO RESPONSIBILITY FOR INJURY OR DAMAGE ARISING FROM THE USE OF THIS SPECIFICATION DIAGRAM.

WIRING CONNECTIONS FOR APPROVED ELECTRIC WATER HEATERS
ONE CUSTOMER WITH MULTIPLE WATER HEATERS

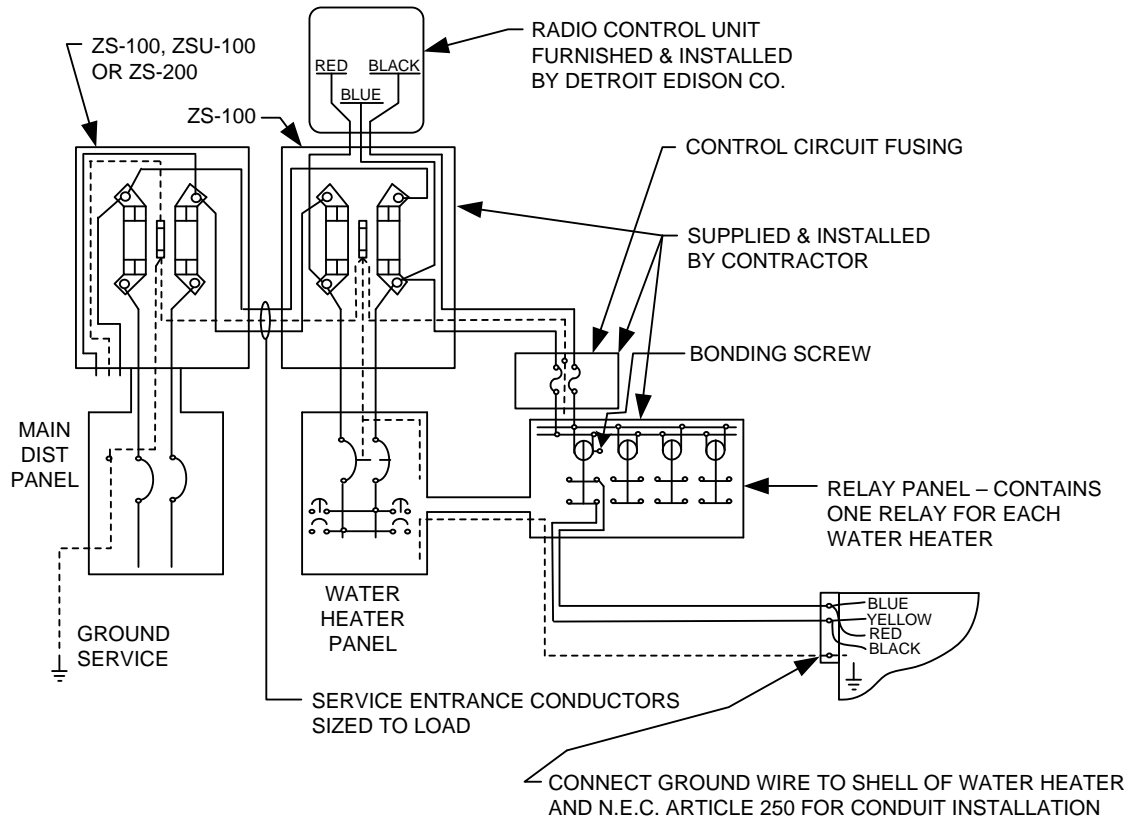

NOTES:

- 1 - SERVICE CONDUCTORS MUST BE INSTALLED TO COMPLY WITH N.E.C. SERVICE ENTRANCE REQUIREMENTS. THIS COULD BE SERVICE ENTRANCE CABLE OR CABLE IN CONDUIT. TYPE UF NMC OR NM NONMETALLIC SHEATHED CABLE IS **NOT** ACCEPTABLE.
- 2 - ALL WIRING SHOULD BE INSTALLED BY AN ELECTRICAL CONTRACTOR.
- 3 - WHEN PLASTIC WATER PIPE IS USED, CONNECT GROUND WIRE TO SHELL OF WATER HEATER THEN CONNECT GROUND WIRE TO THE METALLIC COLD WATER INLET PIPE OF THE WATER HEATER. REFER TO 2005 N.E.C. 250.52 (A) (1) "METAL UNDERGROUND WATER PIPE" AND 2005 N.E.C. 250.32 "BUILDINGS OR STRUCTURES SUPPLIED BY FEEDER(S) OR BRANCH CIRCUIT(S)" AND 547.9 (B) "SERVICE DISCONNECTING MEANS AND OVERCURRENT PROTECTION AT THE BUILDING(S) OR STRUCTURE(S)", (3) "GROUNDING AND BONDING."
- 4 - ALL WIRING MUST COMPLY WITH THE 2005 N.E.C. 422.10, 422.11(1),(3) & 422.13.
- 5 - CONTRACTOR IS RESPONSIBLE FOR AND WILL SUPPLY ALL REQUIRED RELAYS.
- 6 - THE DETROIT EDISON COMPANY ASSUMES NO RESPONSIBILITY FOR INJURY OR DAMAGE ARISING FROM THE USE OF THIS SPECIFICATION DIAGRAM.

FARM MAYPOLE WATER HEATER INSTALLATION FOR DETROIT EDISON CONTROLLED WATER HEATER RATE SINGLE STANDARD WATER HEATER

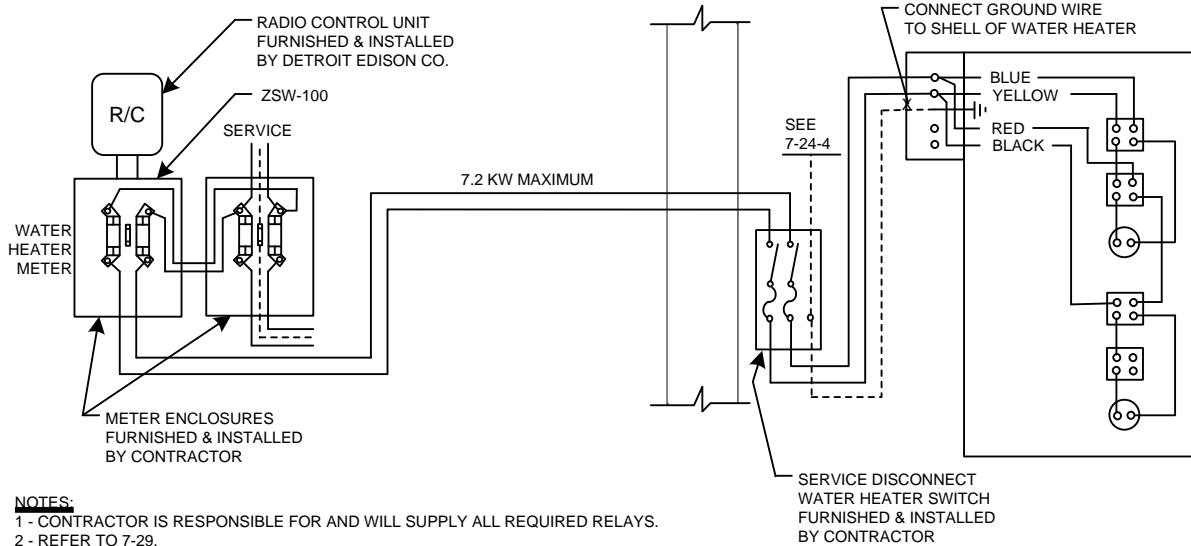

FARM MAYPOLE - WATER HEATER INSTALLATION TWO TO FOUR STANDARD WATER HEATERS IN DIFFERENT LOCATIONS

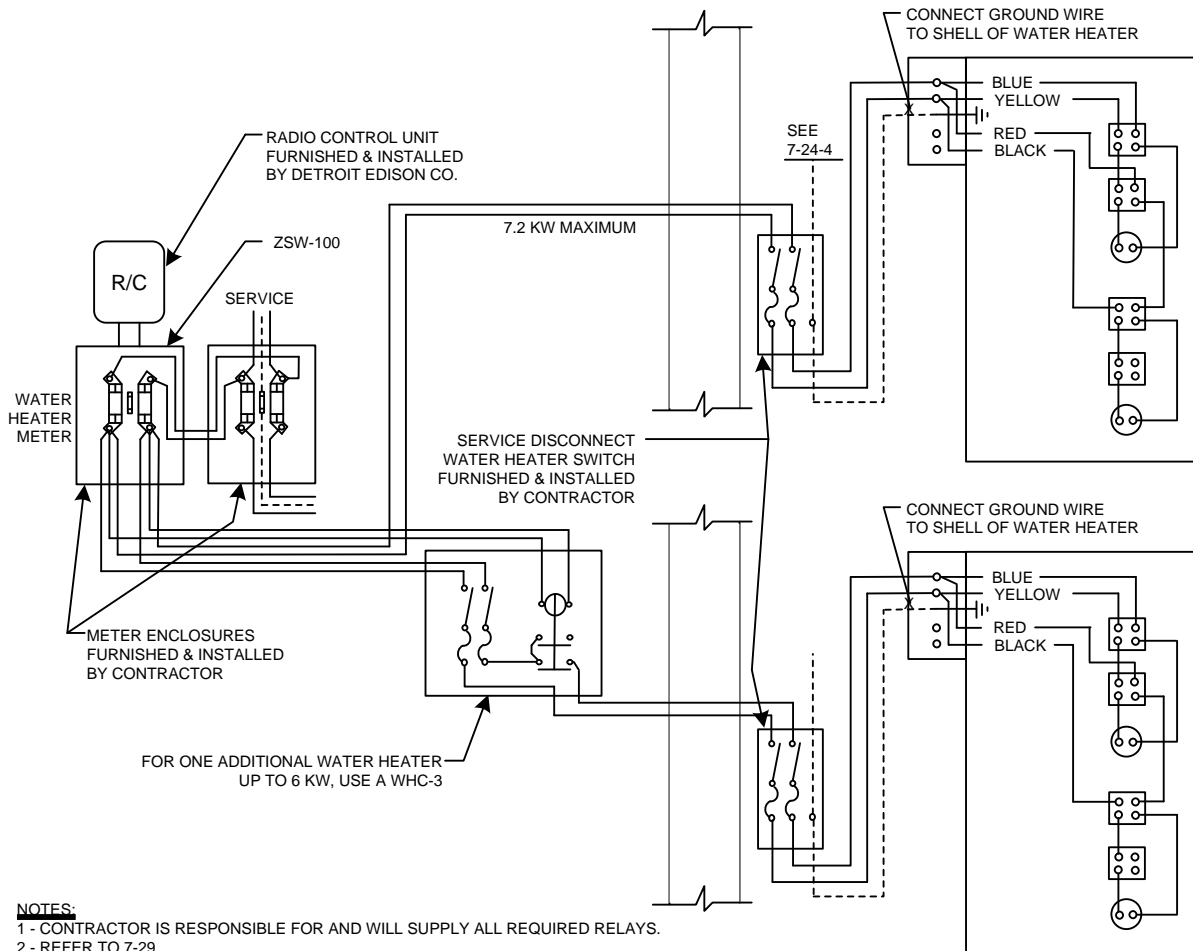

WIRING CONNECTIONS FOR ELECTRIC WATER HEATERS

FARM BUILDING INSTALLATION
REMOTE METERING

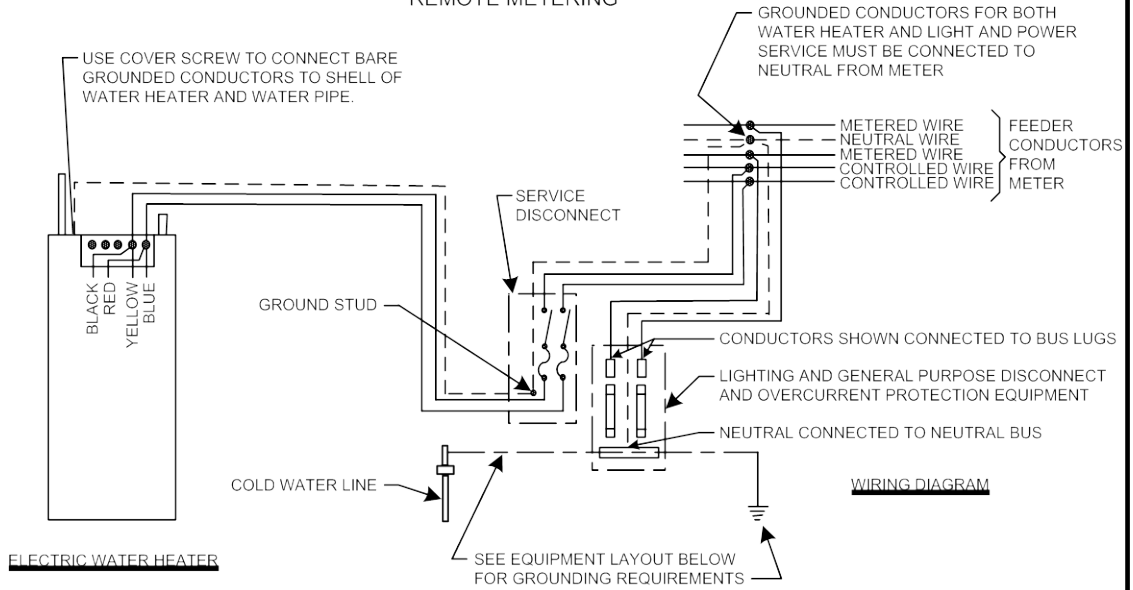

NOTES:

1 - REFER TO 7-29.

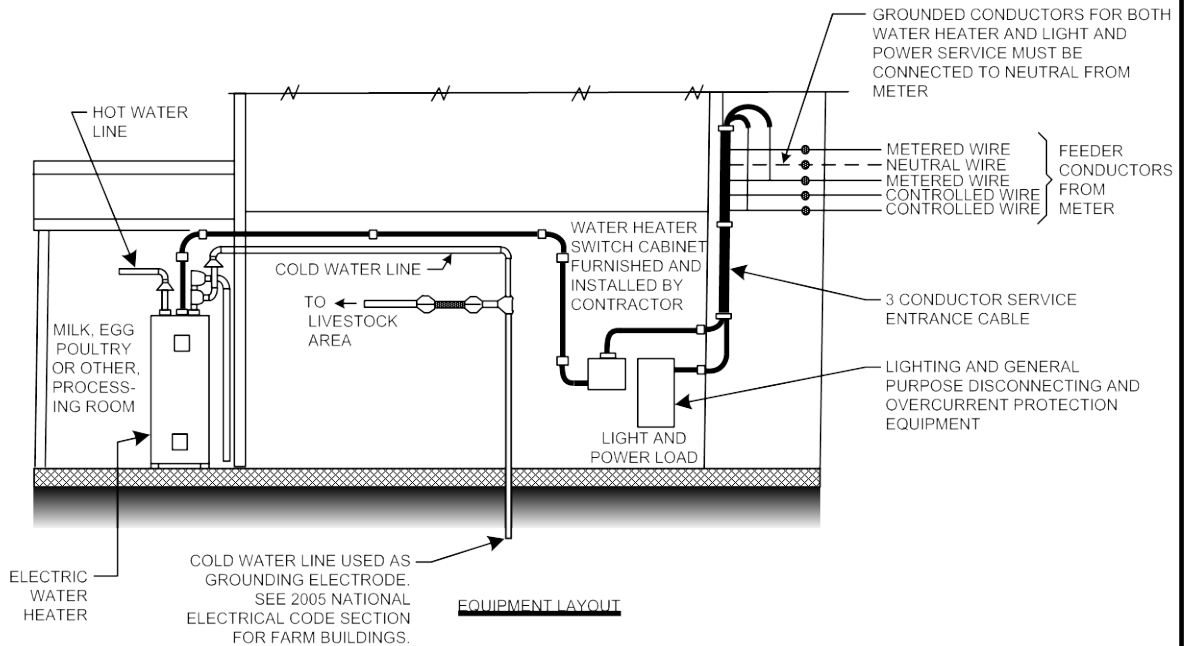

ELECTRIC WATER HEATER WIRING CONNECTIONS
FOR DETROIT EDISON WATER HEATER RATES
IN MULTIPLE OCCUPANCY BUILDINGS
VERTICAL METER STACKS (V.M.S.)

SINGLE WATER HEATER PER METER
THREE OR MORE WATER HEATER CUSTOMERS

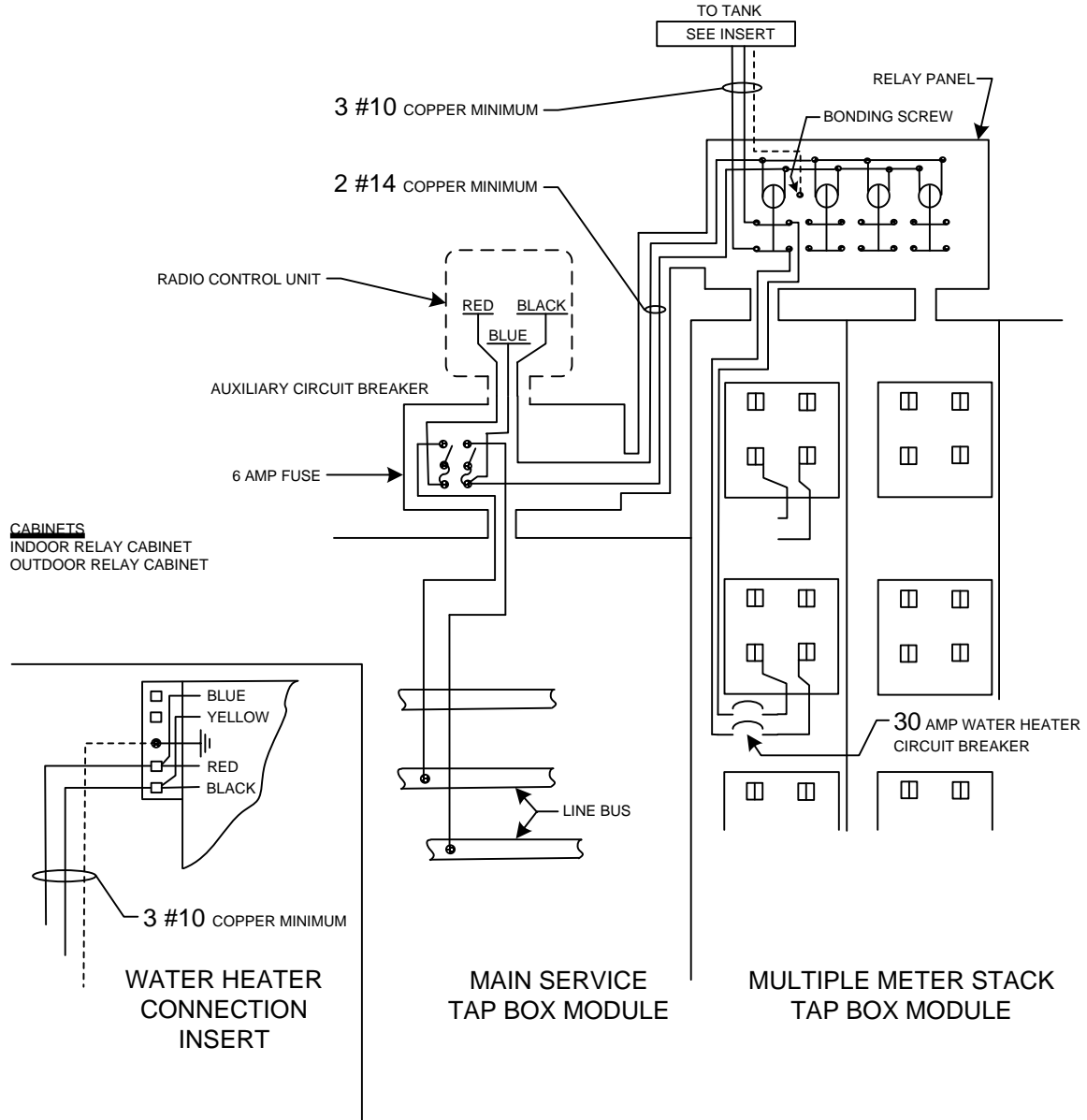

SEE SIM-ESIG PAGE 7-25-2.

THE DETROIT EDISON COMPANY ASSUMES NO RESPONSIBILITY FOR INJURY OR DAMAGE ARISING OUT OF THE USE OF THIS SPECIFICATION DIAGRAM.

ELECTRIC WATER HEATER ASSEMBLY
 FOR DETROIT EDISON WATER HEATER RATES
 IN MULTIPLE OCCUPANCY BUILDINGS
 VERTICAL METER STACKS (V.M.S.)
 SINGLE PHASE – SINGLE STANDARD WATER HEATER

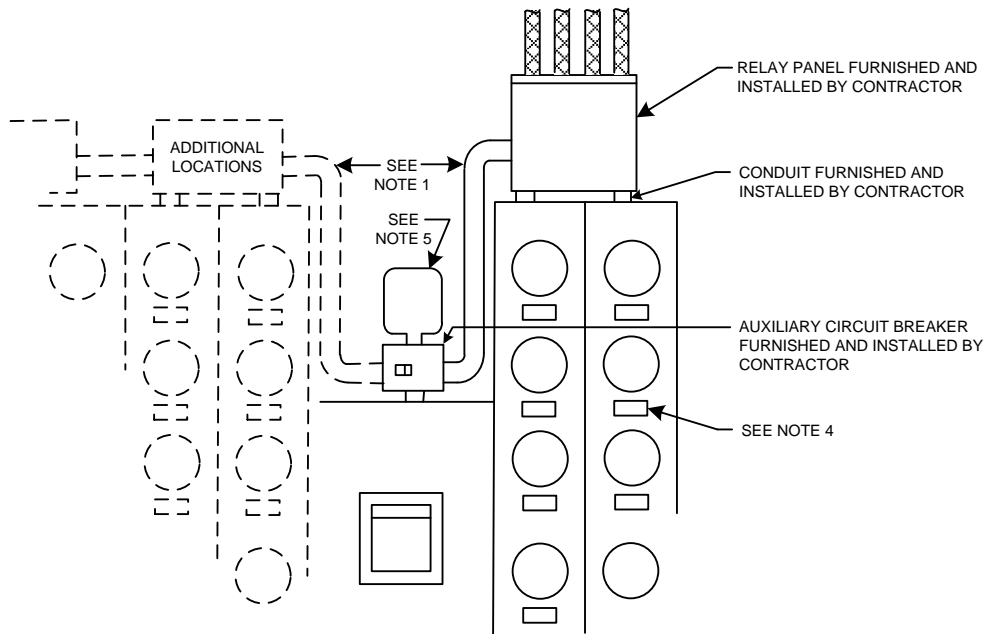

NOTES:

- 1 - CONDUIT WITH 2 #14 COPPER MINIMUM. CONTROL CIRCUIT WIRING FURNISHED AND INSTALLED BY CONTRACTOR.
- 2 - WATER HEATER LOAD CONDUCTORS MAY EXIT THROUGH TOP OF RELAY PANEL OR RETURN THROUGH VERTICAL METER STACK. CONTRACTOR MUST USE NEMA 3R CONDUIT FITTINGS ON OUTDOOR RELAY.
- 3 - WATER HEATER METER POSITION MUST BE VERTICALLY OR HORIZONTALLY ADJACENT TO RESIDENTIAL OR GENERAL SERVICE METER FOR THE SAME CUSTOMER.
- 4 - WATER HEATER WITH A CAPACITY OF 120 GALLONS OR LESS SHALL BE CONSIDERED AS A CONTINUOUS LOAD. REFER TO 2005 N.E.C. 422.10. REFER TO 2005 N.E.C. ARTICLE 210, II. BRANCH-CIRCUIT RATINGS. CONTRACTOR WILL FURNISH AND INSTALL ALL CIRCUIT BREAKERS FOR WATER HEATER CIRCUITS HERE AND ALSO AT ANY OTHER REQUIRED LOCATION.
- 5 - RADIO CONTROL UNIT FURNISHED AND INSTALLED BY DETROIT EDISON COMPANY.
- 6 - CONTRACTOR IS RESPONSIBLE FOR AND WILL SUPPLY ALL REQUIRED RELAYS AND RELAY CABINETS. CONTRACTOR WILL INSTALL ALL RELAY CABINETS.
- 7 - THE DETROIT EDISON COMPANY ASSUMES NO RESPONSIBILITY FOR INJURY OR DAMAGE ARISING OUT OF THE USE OF THIS SPECIFICATION DIAGRAM.

ELECTRIC WATER HEATER WIRING CONNECTIONS
FOR DETROIT EDISON WATER HEATER RATES
INSTALLATION IN MULTIPLE OCCUPANCY BUILDING

SINGLE WATER HEATER PER METER
FOUR OR MORE WATER HEATER CUSTOMERS

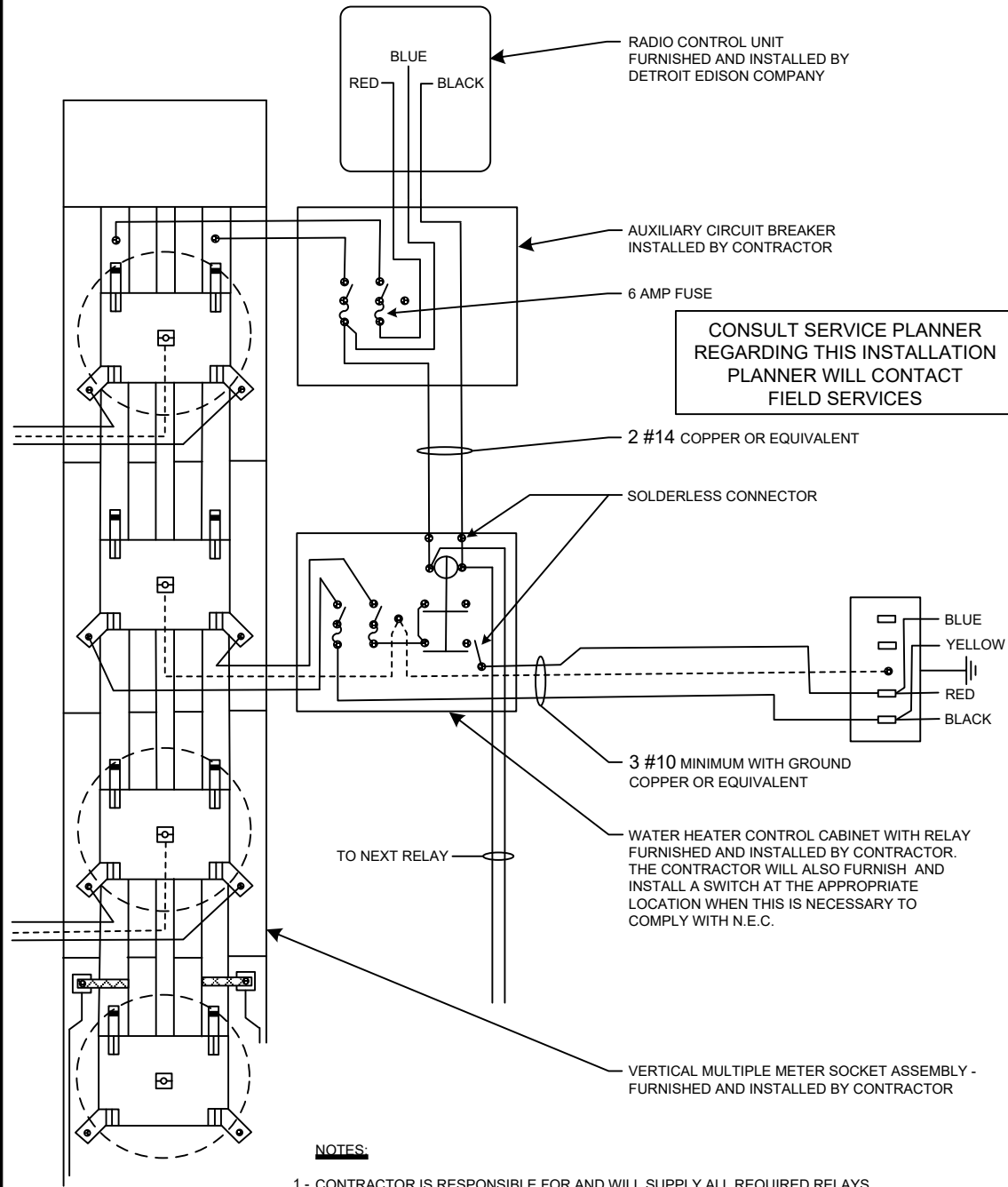

NOTES:

- 1 - CONTRACTOR IS RESPONSIBLE FOR AND WILL SUPPLY ALL REQUIRED RELAYS.
- 2 - DETROIT EDISON COMPANY ASSUMES NO RESPONSIBILITY FOR INJURY OR DAMAGE ARISING OUT OF THE USE OF THIS SPECIFICATION DIAGRAM.

MOBILE HOME PEDESTAL
ELECTRIC WATER HEATER
INSTALLATION

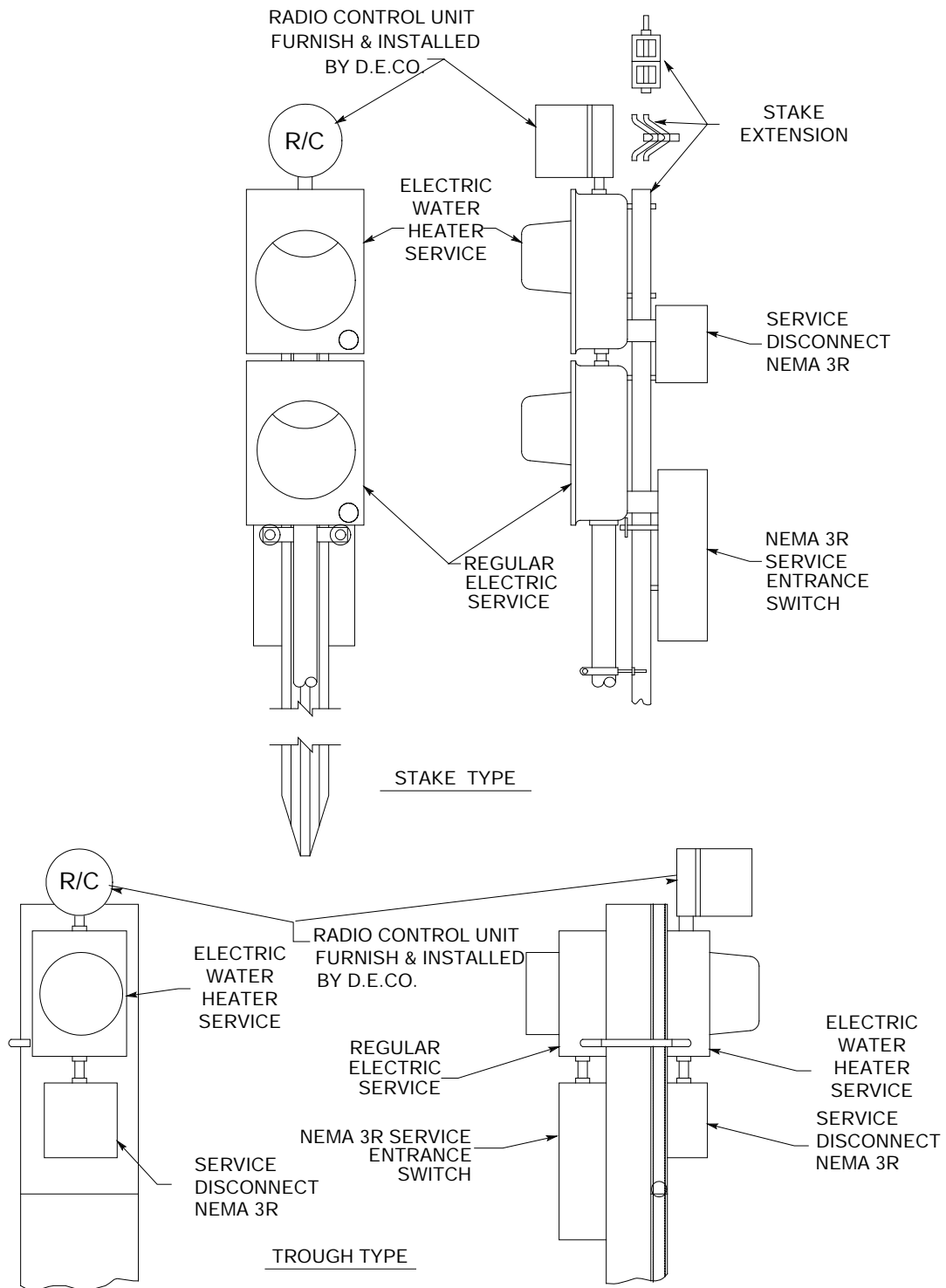

NOTES:

1. THIS IS NOT A PEDESTAL INSTALLATION DRAWING. SEE 3-14-17.
2. SEE 7-27-3 FOR WATER HEATER WIRING CIRCUIT.

**MOBILE HOME MAST OR SERVICE POLE
WATER HEATER INSTALLATION**

MAST

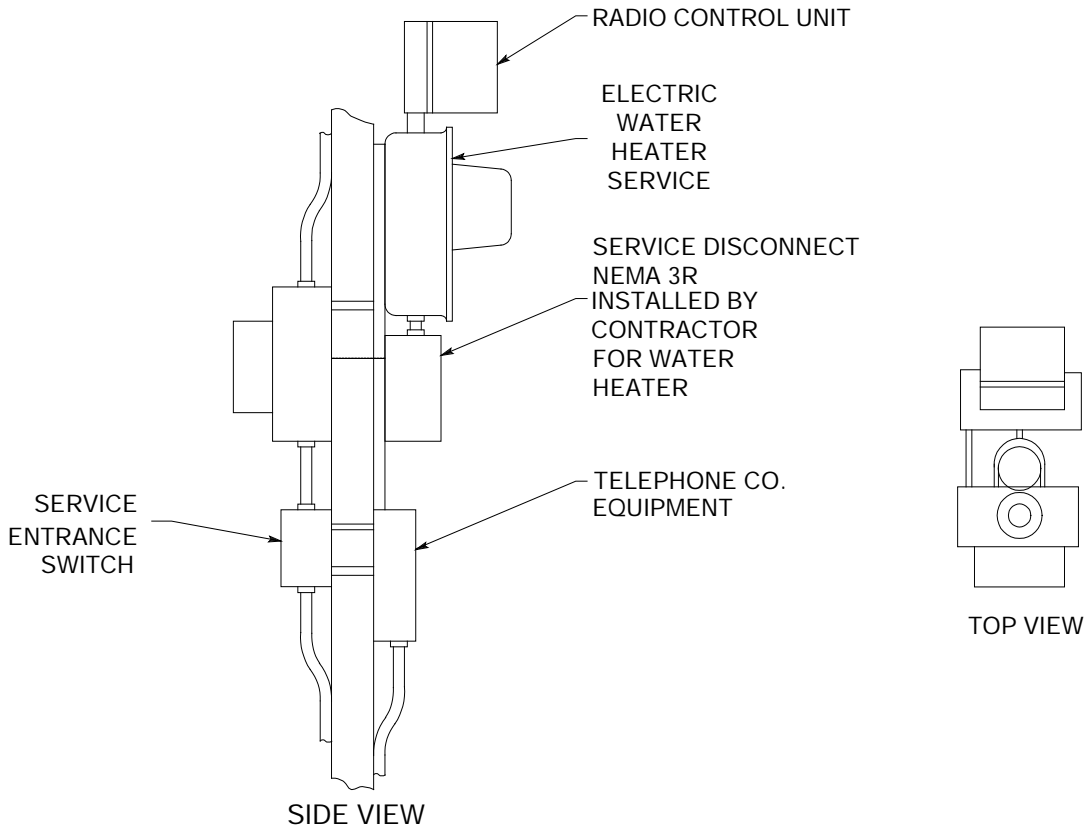

SERVICE POLE (FOR MAINTENANCE ONLY)

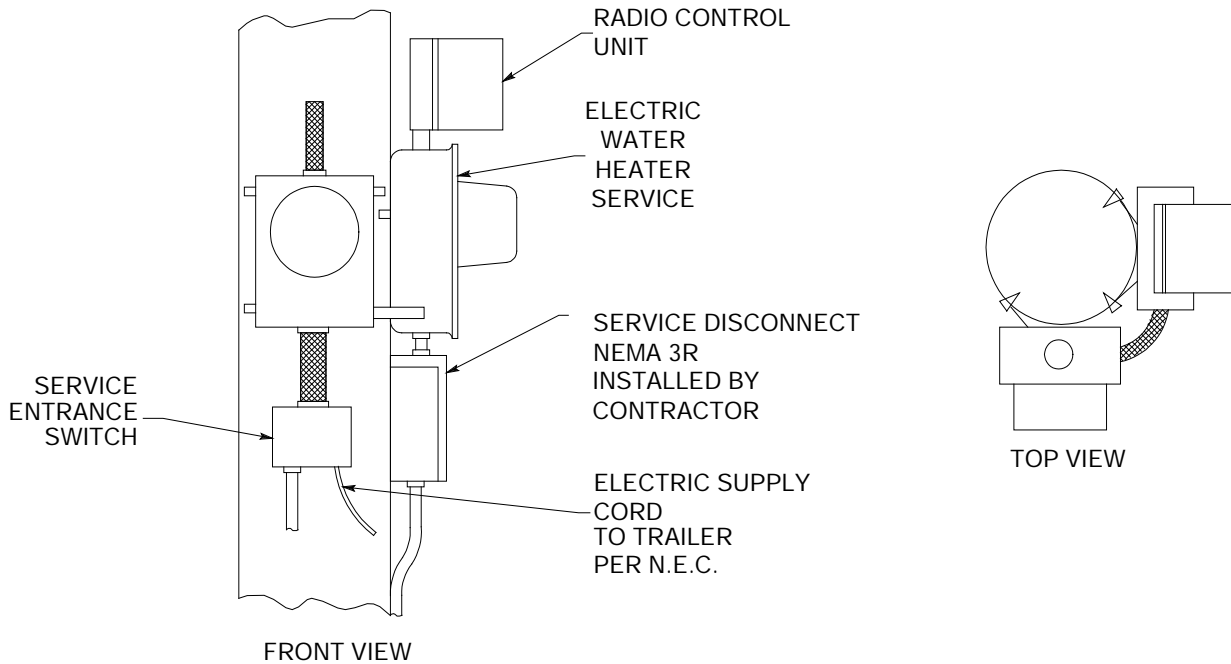

ELECTRIC WATER HEATER WIRING CONNECTIONS
FOR DETROIT EDISON WATER HEATER RATES
IN MOBILE HOME PEDESTAL

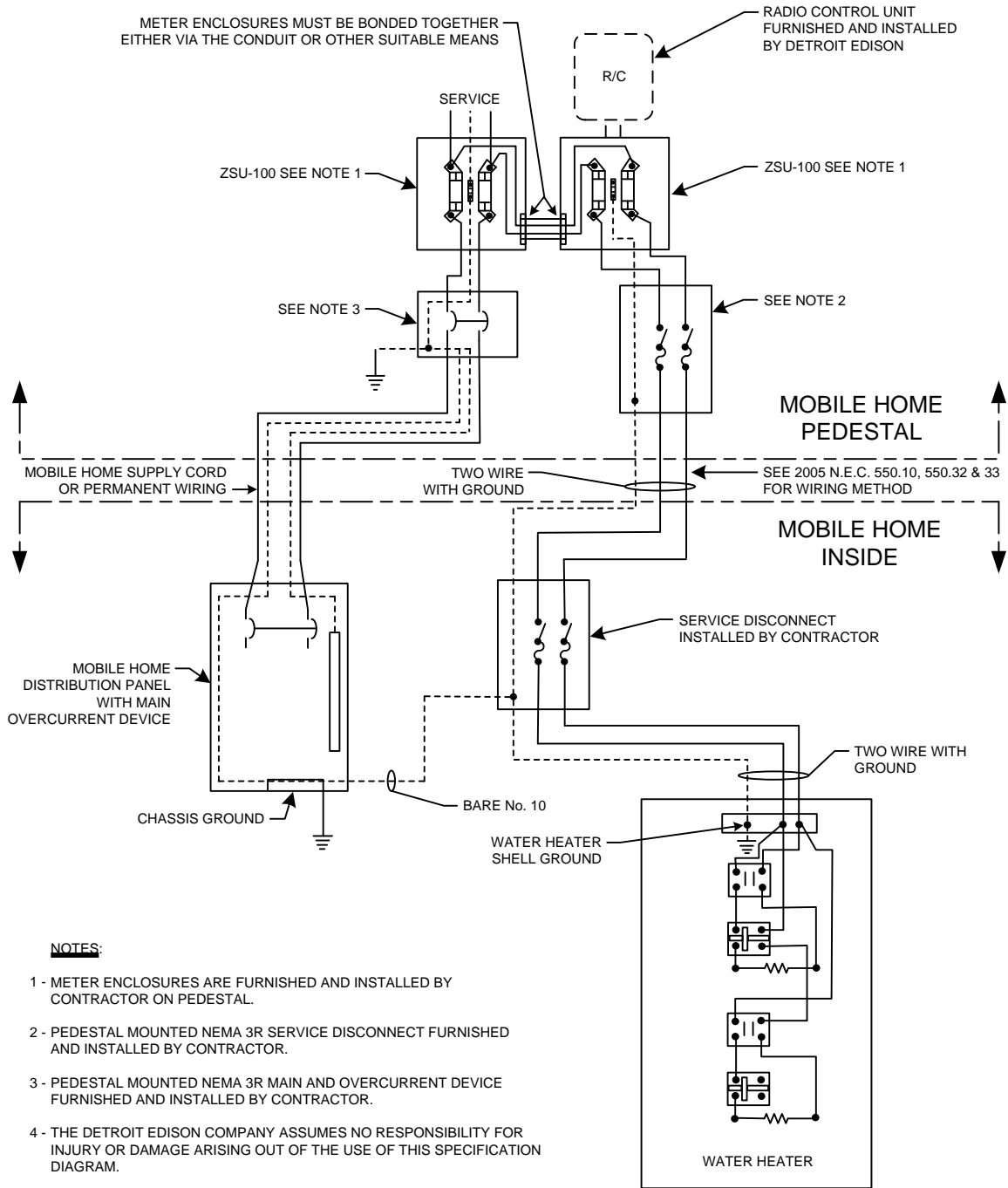

**SPECIFICATIONS FOR MANUFACTURED AND MOBILE HOME ELECTRIC
WATER HEATER INSTALLATION****I. GENERAL**

The Detroit Edison Company will accept 30 gallon or larger water heaters used in manufactured and mobile homes where the home is served by a meter billed on the residential or all electric residential rate. The customer has a choice of residential water heater rate Option I or III. See Rate Book for rate options.

II. INSTALLATION

Permanent wiring to the Manufactured or Mobile Home is required for a separate metered water heater. The wiring shall comply with 2005 NFPA 70, Article 550, "Mobile Homes, Manufactured Homes, and Mobile Home Parks". Wiring shall comply with 2005 NEC 550.32, "Service Equipment." Separate from the permanent service equipment, a NEMA 3R enclosure will be mounted on a pedestal or mast near the meter enclosure. This enclosure will house a water heater service disconnect furnished and installed by an electrical contractor. This arrangement will be in close proximity to the mobile or manufactured home's main electrical service equipment.

III. GROUNDING

Grounding and bonding of the water heater circuit shall comply with 2005 NEC 550.32, "Service Equipment" and local *CODE*. Refer to Wiring Diagram 7-27-3.

WATER HEATER INSTALLATION AND WIRING

NOTES:

- 1.-- METER ENCLOSURE, WATER HEATER SERVICE MAIN AND ALL HARDWARE WILL BE FURNISHED AND INSTALLED BY THE CONTRACTOR. THEY SHALL BE INSTALLED AT THE NEAREST READILY ACCESSIBLE ENTRANCE POINT AND BE GROUPED WITH OTHER SERVICE ENTRANCE EQUIPMENT.
- 2.-- THE WATER HEATER SERVICE MAIN SWITCH CABINET & WIRING SHALL BE FIRMLY SECURED. WHERE CABLE IS RUN AT ANGLES WITH JOISTS, CABLE ASSEMBLIES WITH TWO OR MORE CONDUCTORS OF SIZES 6 AWG AND LARGER AND ASSEMBLIES CONTAINING THREE OR MORE CONDUCTORS OF SIZE 8 AWG AND LARGER SHALL NOT REQUIRE ADDITIONAL PROTECTION WHERE ATTACHED DIRECTLY TO THE BOTTOM OF THE JOISTS. SMALLER CABLES SHALL BE RUN EITHER THROUGH BORED HOLES IN JOISTS OR ON RUNNING BOARDS.
- 3.-- WHERE SUBJECT TO PHYSICAL DAMAGE, CABLE SHALL BE PROTECTED BY CONDUIT, ELECTRICAL METALLIC TUBING, SCHEDULE 80 PVC RIGID NONMETALLIC CONDUIT, PIPE, GUARD STRIPS OR OTHER APPROVED MEANS. FOR TYPE NM AND SE CABLE, BENDS SHALL BE SO MADE, AND OTHER HANDLING SHALL BE SUCH THAT THE CABLE WILL NOT BE DAMAGED AND THE RADIUS OF THE CURVE OF THE INNER EDGE OF ANY BEND SHALL BE NOT LESS THAN FIVE TIMES THE DIAMETER OF THE CABLE. PROVIDE A MINIMUM SPACE OF THREE FEET IN FRONT OF THE WATER HEATER. SEE 2005 NEC 110.26. SPACE ABOUT ELECTRICAL EQUIPMENT.
- 4.-- ALL WIRING SHOULD BE INSTALLED BY AN ELECTRICAL CONTRACTOR. NONMETALLIC-SHEATHED (NMC) AND SERVICE ENTRANCE (SE) CABLE SHALL BE SUPPORTED AND SECURED BY STAPLES, CABLE TIES, STRAPS, HANGERS, OR SIMILAR FITTING DESIGNED AND INSTALLED SO AS NOT TO DAMAGE THE CABLE, AT INTERVALS NOT EXCEEDING 4 1/2 FEET (1.4m) AND WITHIN 12 INCHES (300 mm) OF EVERY OUTLET OR JUNCTION BOX. FLAT CABLES SHALL NOT BE STAPLED ON EDGE.
- 5.-- ADEQUATE SPACE FOR WATER HEATER METER ENCLOSURE (ZSW-100) MUST BE AVAILABLE EITHER SIDE OF SERVICE METER.
- 6.-- THE SERVICE PLANNER AND METER ENGINEERING SHOULD BE CONSULTED ON ANY INSTALLATION NOT COVERED BY THIS INSTALLATION PAGE. THIS COULD INCLUDE A MULTIPLE WATER HEATER INSTALLATION.
- 7.-- ALL INTERIOR WIRING AND PLUMBING TO BE COMPLETED BEFORE CALLING EDISON TO HAVE WATER HEATER PUT IN SERVICE. WATER HEATER MUST BE FULL OF WATER BEFORE ENERGIZING.
- 8.-- LISTED NMC CABLE WILL CONTAIN A GROUNDING CONDUCTOR THAT WILL BE ATTACHED TO THE GREEN GROUNDING SCREW OR OTHER RELIABLE GROUND ON THE WATER HEATER.
- 9.-- THE DETROIT EDISON COMPANY ASSUMES NO RESPONSIBILITY FOR INJURY OR DAMAGE ARISING OUT OF THE USE OF THIS SPECIFICATION DIAGRAM.

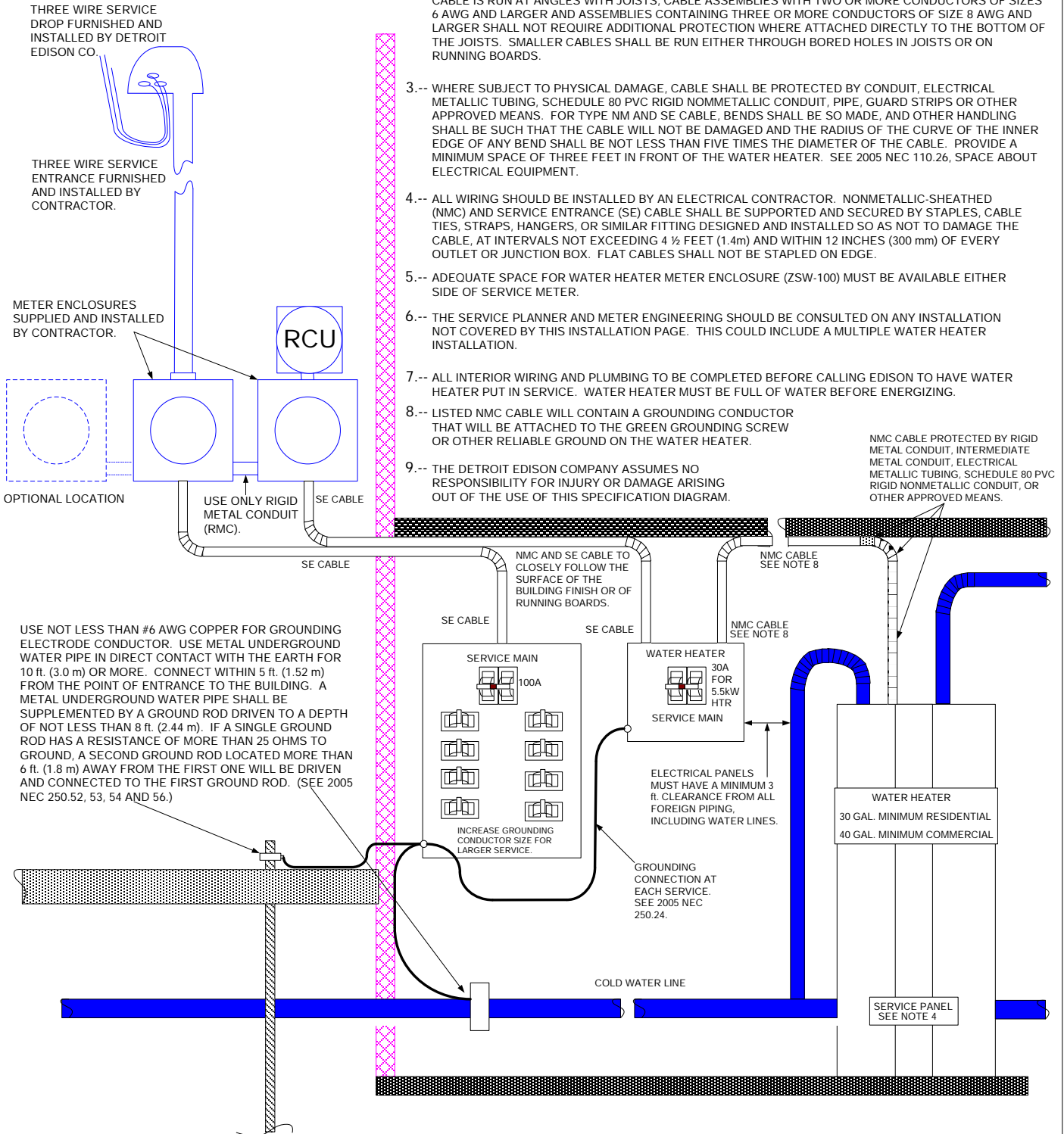

**ELECTRIC WATER HEATERS INSTALLED
IN AGRICULTUREAL BUILDINGS**

I. GENERAL

Farms using electric water heaters will have electrical wiring that will equate with any of four scenarios. It is important to ascertain the existence of these conditions so that the electric water heater can be correctly grounded and bonded back to the water heaters specific rate meter.

Scenario One: The building containing the electric water heater may be supplied by a single feeder from another building.

Scenario Two: The building containing the electric water heater may utilize a service main disconnect within the same building and not be fed from a single "Site-Isolating Device".

Scenario Three: The farm buildings may be fed from a single distribution point utilizing a single "Site-Isolating Device". The "Site-Isolating Device" is pole mounted and supplied from either an overhead or underground service. It is a single disconnect that simultaneously disconnects all ungrounded service conductors from all the farm building(s) or structure(s) premises wiring. It is ahead of the meters. Overcurrent protection is not required. (See 2005 NEC 547.9, "Electrical Supply to Building(s) or Structure(s) from a Distribution Point.")

Scenario Four: Agricultural buildings used for livestock with a cement floor will utilize an "Equipotential Plane". (See 2005 NEC 547.10, "Equipotential Planes and Bonding of Equipotential Planes.")

II. GROUNDING REQUIRMENTS

The following grounding and bonding practices **must** be observed to insure a safe electric water heater installation.

- a. In scenario one the water heater service will parallel the existing single feeder. A grounding conductor that attaches to the green grounding screw or other reliable ground on the electric water heater will be insulated and separately wired back with the water heater service. This circuit will also be connected in the building containing the water heater as follows. To the building ground electrode system and, if an "Equipotential Plane" exists in the building containing the water heater, to the "Equipotential Plane". The electric water heaters service main disconnect will be grouped with the feeder's service main at the electric feeders' supply building. (See 2005 NEC 250.32 (B) (1), Also 547.10 (A) and (B). See Page 7-29-4.

- b. In scenario two a single “Site-Isolating Device” is **not** utilized, and the building contains its own service main disconnect. The water heater grounding and bonding will comply with the following. A grounding conductor that attaches to the green grounding screw or other reliable ground on the electric water heater will be connected to the building’s ground electrode system, and if used, the “Equipotential Plane”. **Neutral will be bonded to the building’s ground electrode system.** (See 2005 NEC 250.32 (B) (2), Also 547.10 (B). See Page 7-29-4.
- c. If a single “Site-Isolating Device” **is** utilized, a grounding conductor that attaches to the green grounding screw or other reliable ground on the electric water heater must be continuous and connected to the neutral terminal at the electric water heater’s separate meter. (See 2005 NEC 250.142, “Use of Grounded Circuit Conductor for Grounding Equipment.”, (B) “Load-Side Equipment.”, Reference to 250.32 (D), 547.9 (B) (1) (a).) See Page 7-29-5.

III. ADDITIONAL GROUNDING REQUIRMENTS

- a. “Equipotential Planes” must be installed in all concrete floor confinement areas of livestock buildings that contain metallic equipment that is accessible to animals and likely to become energized. Outdoor concrete confinement areas, such as feedlots, must have “Equipotential Planes” installed around metallic equipment that is accessible to animals and likely to become energized. The “Equipotential Plane” must encompass the area around the equipment where the animal stands while accessing the equipment. The “Equipotential Plane” must be bonded to the building or structure electrical grounding system and any metallic parts, including metallic piping, which is likely to become energized. All metallic parts of water heaters must present a low resistive path to any “Equipotential Planes” that encompass them. See Page 7-29-5.
- b. An “Equipotential Plane” is not used in a dirt confinement area. **All** circuits providing electric power to equipment that is accessible to animals in a dirt confinement area **must** have GFCI protection. (See 2002 NEC 547.10 (B).)

IV. UPGRADE OF OLD INSTALLATIONS

- a. The use of insulating couplings or grounding of piping shall not be the sole means of grounding or isolating a water heater. Water or other metal piping that is in contact with earth for more than 10 feet shall not be used as the sole means of grounding a water heater. Consider how the building is wired when upgrading the water heaters grounding and bonding. (See 2005 NEC 250.52 (A) (1), “Metal Underground Water Pipe”.)

- b. Water heater grounding shall conform to 2005 NEC 250.32, “Buildings or Structures Supplied by Feeder(s) or Branch Circuit(s)”, and 547.9 (B), “Service Disconnecting Means and Overcurrent Protection at the Building(s) or Structure(s)”, (3) “Grounding and Bonding.”

V. GROUNDING AND BONDING COMPLIANCE

The complete wiring system shall comply with **ALL** grounding and bonding requirements of the current National Electrical *CODE*. All ungrounded and purposely grounded wiring shall also comply with **ALL** *CODE* requirements.

**THE DETROIT EDISON COMPANY ASSUMES NO
RESPONSIBILITY FOR INJURY OR DAMAGE ARISING
FROM THE USE OF THESE SPECIFICATIONS.**

ELECTRIC WATER HEATER INSTALLED IN AGRICULTURAL BUILDINGS

SCENARIO ONE

BUILDING SUPPLIED BY A SINGLE FEEDER FROM ANOTHER BUILDING.

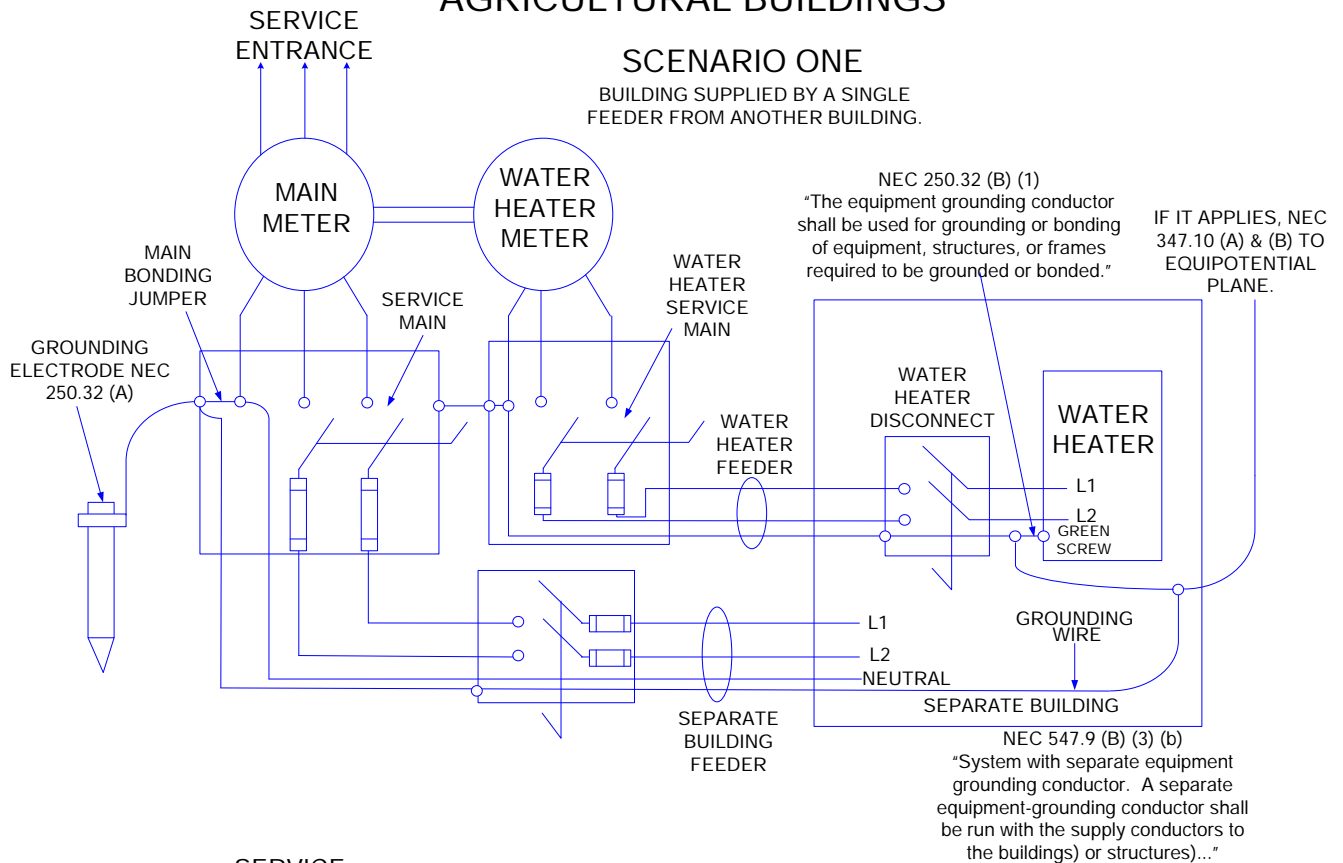

SCENARIO TWO

NO SITE-ISOLATING DEVICE, BUILDING HAS OWN SERVICE MAIN

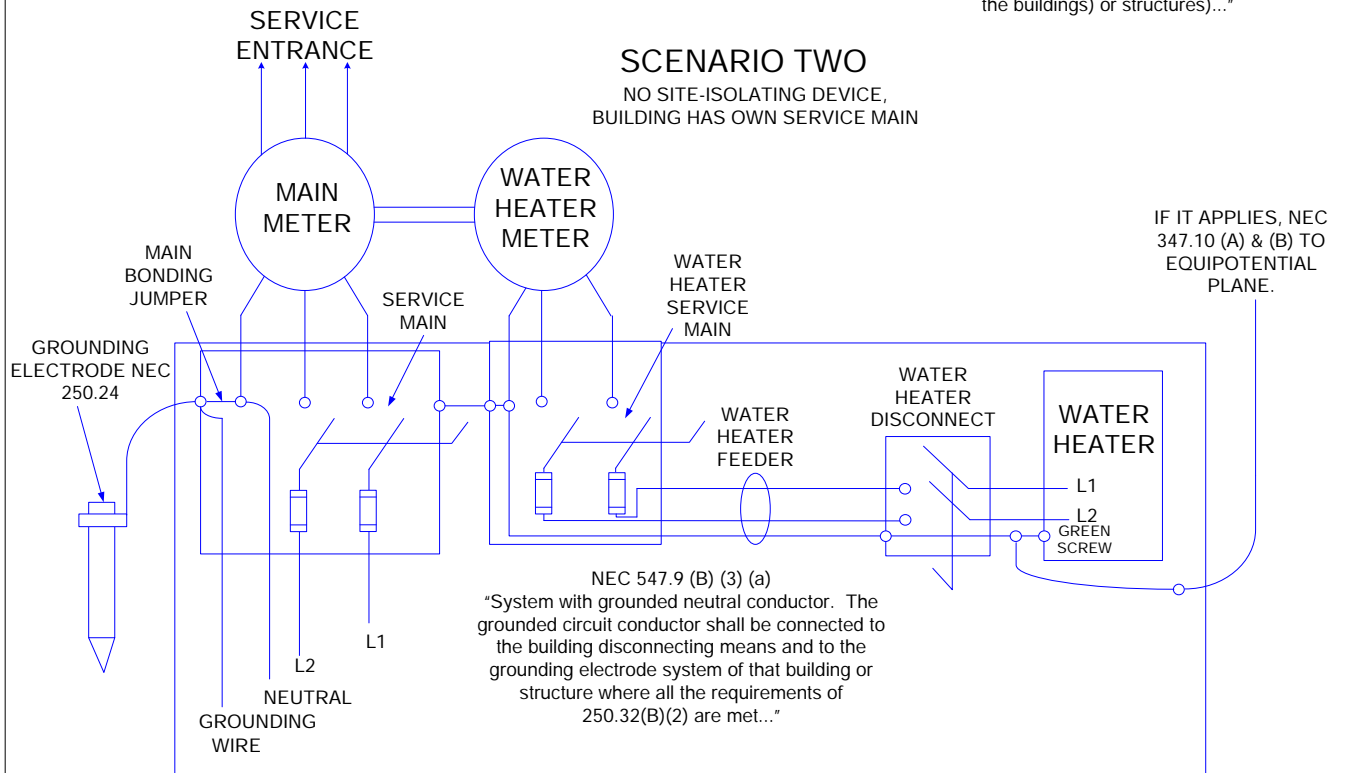

ELECTRIC WATER HEATER INSTALLED IN AGRICULTURAL BUILDINGS

SCENARIO THREE

SINGLE SITE-ISOLATING DEVICE IS UTILIZED.

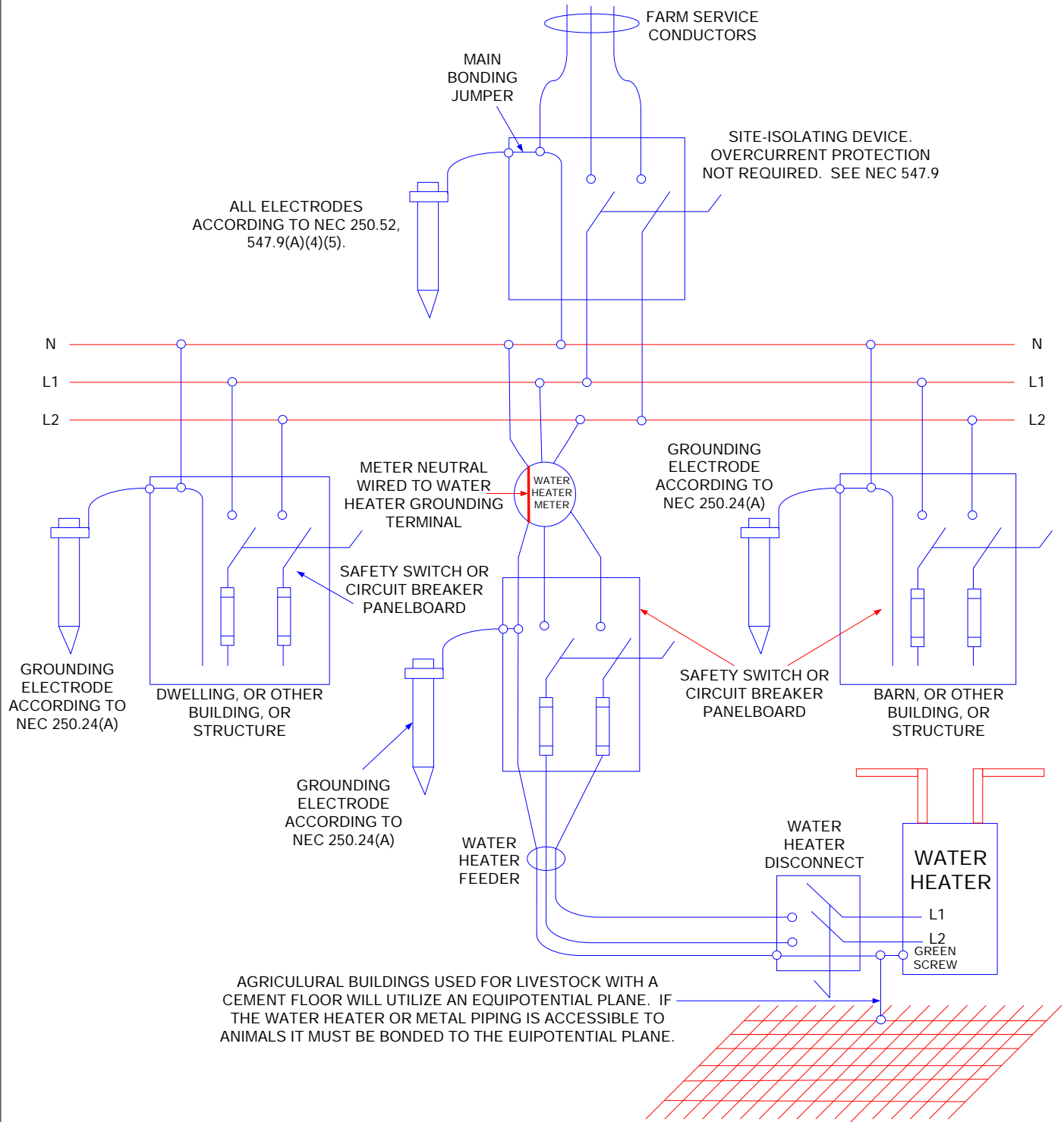

AGRICULTURAL BUILDINGS USED FOR LIVESTOCK WITH A CEMENT FLOOR WILL UTILIZE AN EQUIPOTENTIAL PLANE. IF THE WATER HEATER OR METAL PIPING IS ACCESSIBLE TO ANIMALS IT MUST BE BONDED TO THE EQUIPOTENTIAL PLANE.

AN EQUIPOTENTIAL PLANE IS AN AREA WHERE WIRE MESH OR OTHER CONDUCTIVE ELEMENTS ARE EMBEDDED IN OR PLACED UNDER CONCRETE, BONDED TO ALL METAL STRUCTURES AND FIXED NONELECTRICAL EQUIPMENT THAT MAY BECOME ENERGIZED, AND CONNECTED TO THE ELECTRICAL GROUNDING SYSTEM.

WATER HEATER
SINGLE (ECO) WIRING DIAGRAM

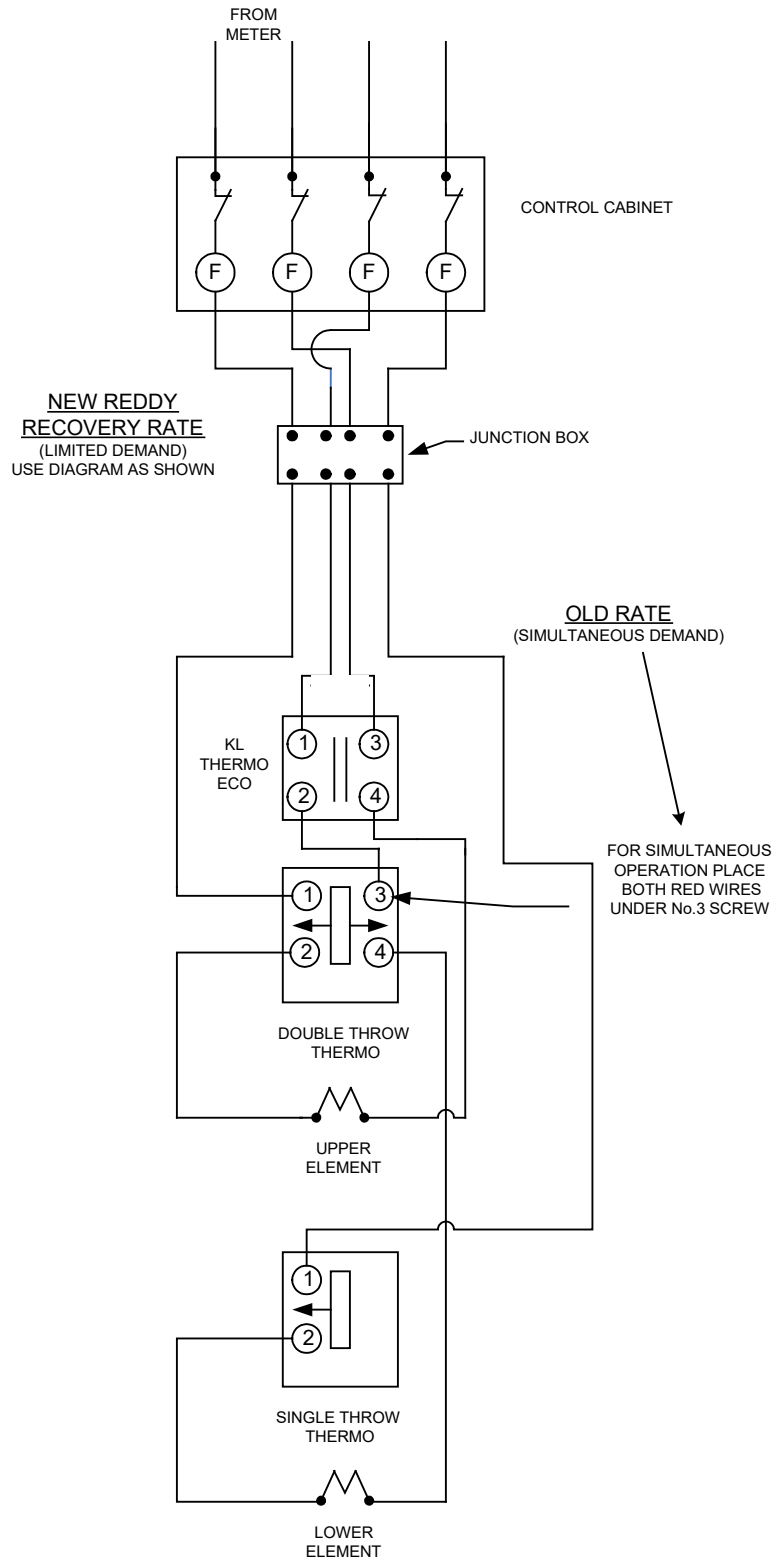

WATER HEATER DOUBLE (ECO) WIRING DIAGRAM

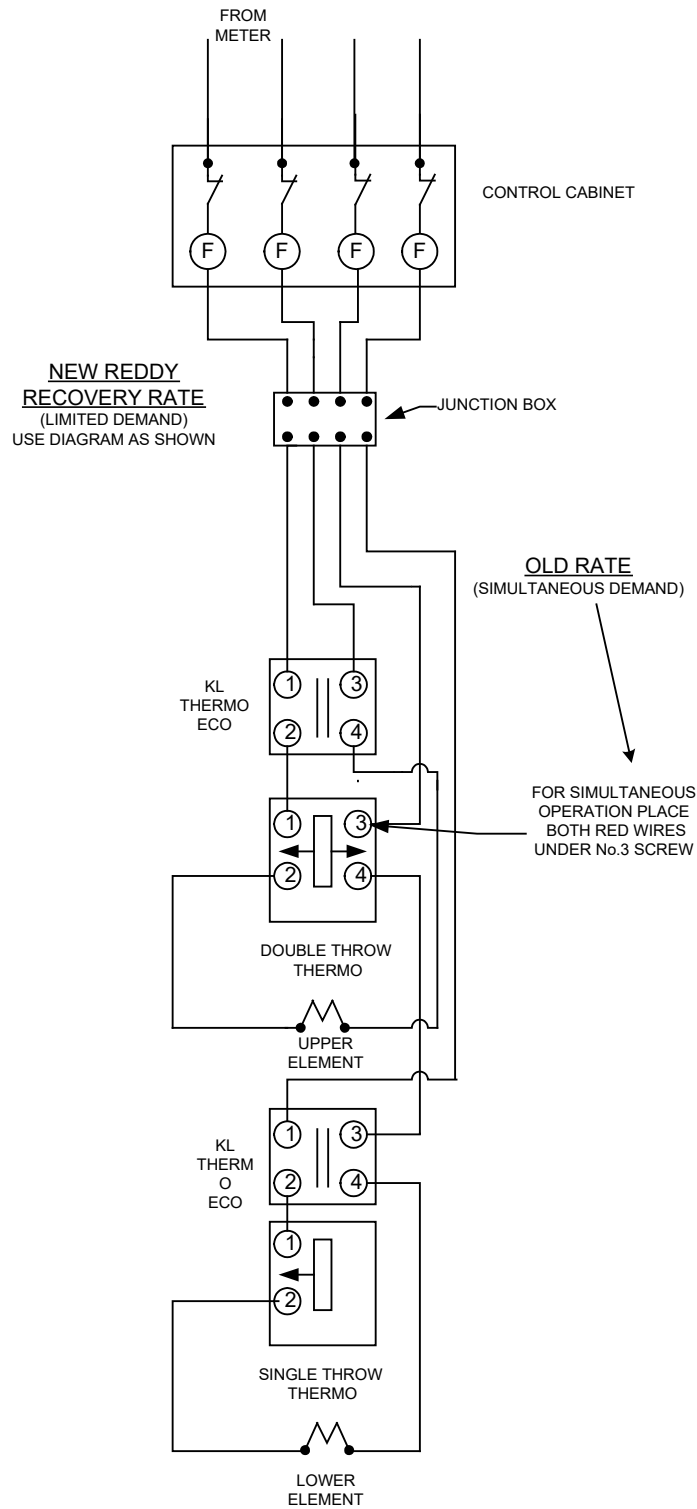

WATER HEATER CIRCUIT

